



USER MANUAL

SELF-CLEANING MESH FILTER HYDRAULIC-200-H-INOX

Serial number: _____

Purchase date: _____



INDEX

1.	INTRODUCTION.....	1
1.1	Filter identification.....	1
1.2	Basic concepts.....	1
2.	QUALITY CONTROL.....	2
3.	DATA SHEET.....	3
3.1	Mesh filter HYDRAULIC-200-H-INOX.....	3
3.2	Dimensions.....	4
3.3	Hydraulic circuit HYDRAULIC-200-H-INOX.....	5
4.	INSTALLATION.....	6
5.	OPERATION.....	6
6.	MAINTENANCE AND SPARE PARTS.....	7
6.1	Maintenance.....	7
6.2	Exploded view.....	8
6.3	Exploded view table.....	9
7.	CONTROL PANEL.....	10
7.1	Features listing.....	10
7.2	How to program the controller.....	11
7.3	The chain of editable fields.....	11
7.4	Wash time.....	12
7.5	DP preset value.....	12
7.6	Wash mode.....	12
7.7	Accumulations.....	12
7.8	Setup.....	13
7.9	Handling endless loop problems.....	14
7.10	Handling low pressure.....	14
7.11	Connecting the DP sensor to the filter system.....	14
7.12	Low battery.....	14
7.13	Manual activation.....	14
7.14	Timing diagram.....	15
7.15	Wiring diagram.....	16
7.16	Technical data.....	18
8.	PRODUCT WARRANTY.....	19

1. INTRODUCTION

First of all, we want to thank you for purchasing this filter, the result of the work of a group of people committed to offering the correct solution to each filtration process. All products designed and manufactured by ITM Filters meet self-imposed requirements for quality, efficiency and durability. This philosophy is accredited through certification by external bodies.

The highest efficiency of the system is obtained with correct operation and maintenance, please properly follow the indications in this manual throughout the life of the product. We invite you to visit our website: www.itmfilters.com for more information about our products and our company policies.

1.1 Filter identification

The filter is identified with the following nameplate:



IMAGE 1

1.2 Basic concepts

Filtration surface: Area that allows water to pass while retaining suspended particles.

Recommended flow: Optimal filtration must take into account the quality of the source water and its use. The quality of the source water is divided into 4 sections, which have maximum theoretical flows. The sectorization corresponds to the particles per million in the water.

0. Stretch 1: 0-50ppm.
1. Stretch 2: 50-100ppm
2. Stretch 3: 100/200ppm.
3. Stretch 4: > 200ppm.

Loss of pressure (HEAD LOSS): It is the difference in load produced between two points of the same flow. The friction of the water with the filter medium produces a loss of energy. The substances are trapped in the mesh generating a decrease in the porosity of the filter medium, which causes an increase in the pressure drop. The pressure drop measurement is carried out by means of a pressure tap on the inlet manifold and another one on the outlet manifold.

2. QUALITY CONTROL

The entire manufacturing process has been carried out in accordance with the applicable European Directives: Directive 2006/42 / CE on Machines-Annex IIA, Directive 2014/68 / EU on Pressure Equipment and Directive 2014/35 / EU on Electrical Material.

These quality requirements are accredited through certification by external organizations:



3. DATA SHEET

3.1 Mesh filter HYDRAULIC-200-H-INOX



IMAGE 2

MODEL	Ø1/Ø0	Flow (m3/h)					Filtration Surface (cm ²)	Water Consumption per Wash (l)	Net Weight (kg)
		Flow Max.	<50ppm	50/100 ppm	100/200 ppm	Min. Flow			
HYDRAULIC-204-H-INOX	Flange 4"	205	93	76	57	9	5725	50	129
HYDRAULIC-206-H-INOX-Compact	Flange 6"	250	133	105	80	9	5725	50	132
HYDRAULIC-206-H-INOX	Flange 6"	275	163	123	92	20	8528	109	140
HYDRAULIC-208-H-INOX-Compact	Flange 8"	360	220	160	125	20	8528	109	143
HYDRAULIC-208-H-INOX	Flange 8"	415	253	194	142	33	11330	180	163
HYDRAULIC-210-H-INOX-Compact	Flange 10"	510	295	240	123	33	11330	180	167
HYDRAULIC-210-H-INOX	Flange 10"	585	323	273	195	43	14135	235	177
HYDRAULIC-212-H-INOX-Compact	Flange 12"	645	355	300	215	43	14135	235	181

TABLE 1

}
 Working pressure
 min. 2,5 kg/cm²
 máx. 10 kg/cm²
}

Manufacturing technical characteristics:

- Materials:
 - Stainless steel metal components.
 - A2 stainless steel screws.
 - Mesh cartridge : Injected plastic structure with AISI-316 Stainless Steel.
Filtration degree: 125 microns.
 - Grinding cartridge: AISI-304 Stainless Steel.
 - EPDM gaskets: 60 SHORE.
- Superficial treatment:
 - Surface shot blasting up to SA ½ grade.
- Working characteristics:
 - Maximum operating temperature 50°C.
- Commercial components:
 - 1" Suction Cup and 2" Flushing Valve.
 - Battery powered programmer.

3.2 Dimensions

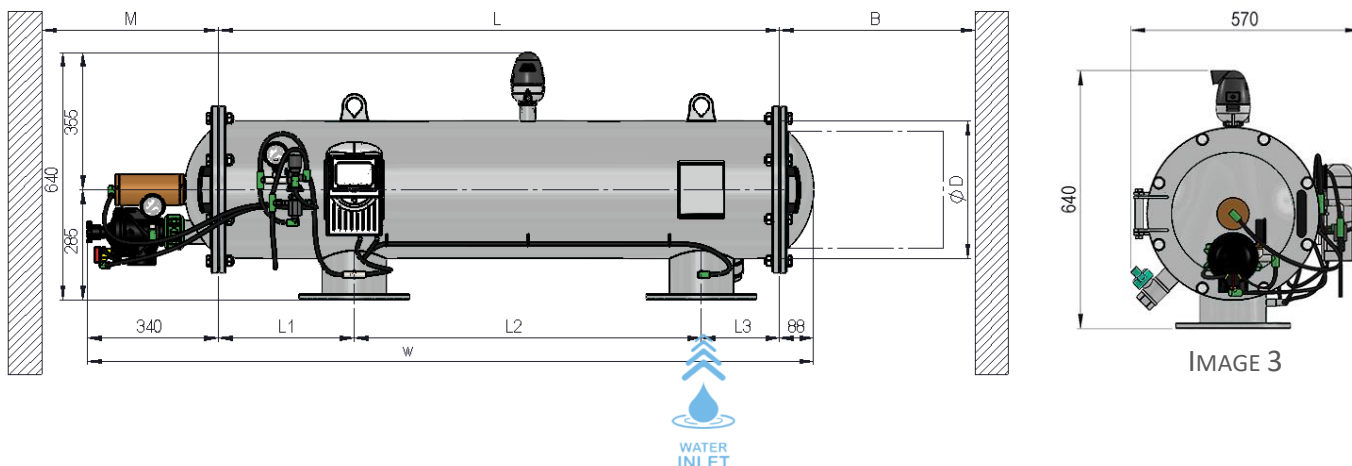

MODEL	Dimensions (mm)							
	ØD	L	L1	L2	L3	W	M	B
HYDRAULIC-204-H-INOX	355	1170	197	770	203	1580	400	1015
HYDRAULIC-206-H-INOX-Compact	355	1170	197	770	203	1580	400	1015
HYDRAULIC-206-H-INOX	355	1455	352	900	203	1865	400	1300
HYDRAULIC-208-H-INOX-Compact	355	1455	352	900	203	1865	400	1300
HYDRAULIC-208-H-INOX	355	1741	438	1100	203	2150	400	1585
HYDRAULIC-210-H-INOX-Compact	355	1741	438	1100	203	2150	400	1585
HYDRAULIC-210-H-INOX	355	2027	446	1370	211	2435	400	1870
HYDRAULIC-212-H-INOX-Compact	355	2027	446	1370	211	2435	400	1870

TABLE 2

MODEL	General Data			
	Nozzle Units	ØAuto Flushing Valve	ØManual Exhaust Valve	Wash Time
HYDRAULIC-204-H-INOX	4	2"	1-½"	30
HYDRAULIC-206-H-INOX-Compact	4	2"	1-½"	30
HYDRAULIC-206-H-INOX	6	2"	1-½"	30
HYDRAULIC-208-H-INOX-Compact	6	2"	1-½"	30
HYDRAULIC-208-H-INOX	8	2"	1-½"	30
HYDRAULIC-210-H-INOX-Compact	8	2"	1-½"	30
HYDRAULIC-210-H-INOX	10	2"	1-½"	30
HYDRAULIC-212-H-INOX-Compact	10	2"	1-½"	30

TABLE 3

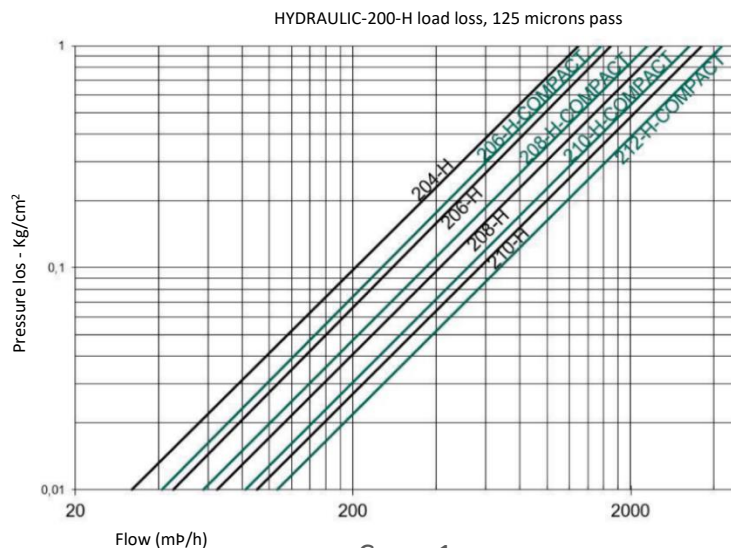

CHART 1

3.3 Hydraulic circuit HYDRAULIC-200-H-INOX

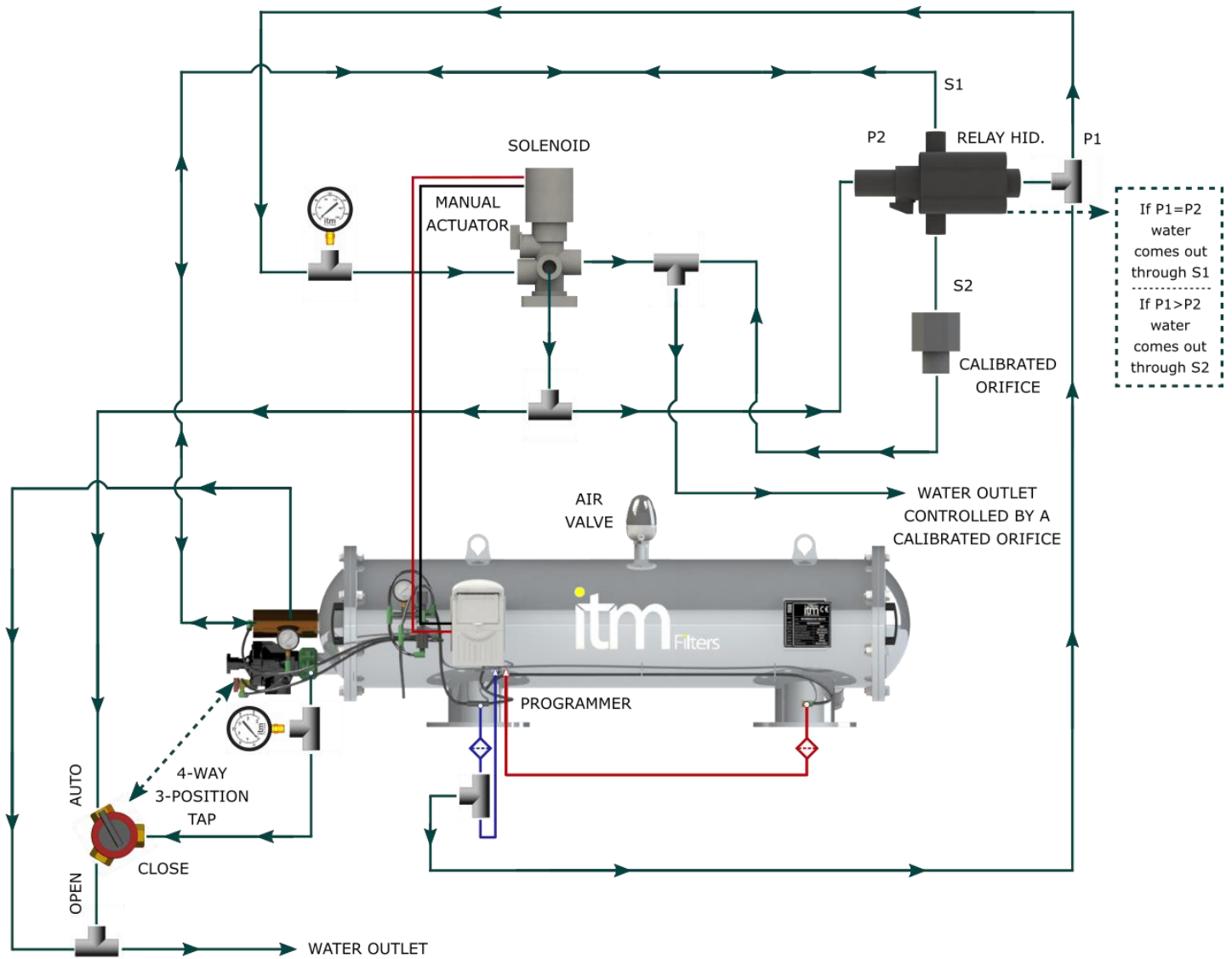

IMAGE 4

* Where P1 is the water inlet pressure and P2 is the water outlet pressure.

* The 4-way tap has 3 positions:

- *AUTO* : filter operation with automatic cleaning.
- *OPEN* : cleaning cycle
- *CLOSE* : filter operation (without automatic cleaning)

4. INSTALLATION

1. Place the filter on an accessible flat surface and in the correct flow direction.
2. Position the inlet and outlet manifolds, fixing the flanges with their corresponding gaskets.
3. Check that the drain outlet is directed to the desired area.
4. Check that the unions are tight, turn on the water supply and verify that there is no leak.
5. Filtering. Open the water flow at the recommended flow rate and at a working pressure between 2.5-10 kg/cm².
6. Cleaning. When the pressure gauge indicates a pressure difference equal to or greater than 0,3 kg/cm², the automatic filter cleaning will begin, without interrupting the water filtering process. The cleaning cycle leaves the factory with a duration of 30 seconds, it must be adjusted during installation as it depends on the working pressure. For the cleaning to be automatic, the key must be in the "AUTO" position.

* Note: Place a check valve at the outlet of the filter, to avoid reverse flows and internal breaks in the filter.

5. OPERATION

Mesh filtering consists of the physical separation between water and the substances that are suspended in it. Water flows from the inside of the filter cartridge to the outside, causing dirt to accumulate on the inside of the filter cartridge.

When the mesh filter becomes clogged, it produces a pressure difference between the inlet and outlet manifolds. The automatic cleaning cycle starts when it reaches a pressure difference of 0.3 kg/cm². To check that the cleaning cycle is correct, it can be started manually by placing the key in the "OPEN" position.

Cleaning process. As soon as a pressure difference of 0,3 is reached or when 12 hours of operation have elapsed, the programmer sends the cleaning activation signal. The signal is sent to the solenoid. The solenoid triggers the hydraulic control system, opens the flushing valve, and communicates the hydraulic cylinder chamber with atmospheric pressure. This has two effects:

7. The water flows through the nozzles arranged in the scanner and it is expelled through the turbine. As a result, the water carries the dirt off the screen and in turn causes the scanner to rotate. That is, the mesh is cleaned around the entire circumference of the cartridge by the pressure difference.
8. The expulsion of the water from the cylinder is carried out in a controlled way thanks to a hydraulic calibrated orifice. The advance of the scanner and the nozzles is regulated by this component, so check that the correct calibrated orifice is installed according to the working pressure of the filter.

	PRESSURE RANGE									
	2Kg/cm ²	3Kg/cm ²	4Kg/cm ²	5Kg/cm ²	6Kg/cm ²	7Kg/cm ²	8Kg/cm ²	9Kg/cm ²	10Kg/cm ²	
Ø ORIFICE	0,9 mm					0,8 mm				
COLOUR	BLACK					WHITE				

TABLE 4

The joint hydraulic action of the turbine and the hydraulic cylinder guarantees the sweeping of the nozzles throughout the filter cartridge.

The pressure difference that occurs between the cleaning chamber (chamber where the turbine is located) and the filtration chamber must not exceed 2,5 kg/cm². This pressure difference is read during the cleaning process, by subtracting between the two filter pressure gauges.

A higher pressure difference can lead to deterioration of the filter cartridge. To regulate the pressure difference, the cleaning valve must be adjusted.

The technology used in the manufacture of the HYDRAULIC-200-H-INOX filter offers high filtration surfaces with compact lengths, due to the maximization of the filter cartridge.

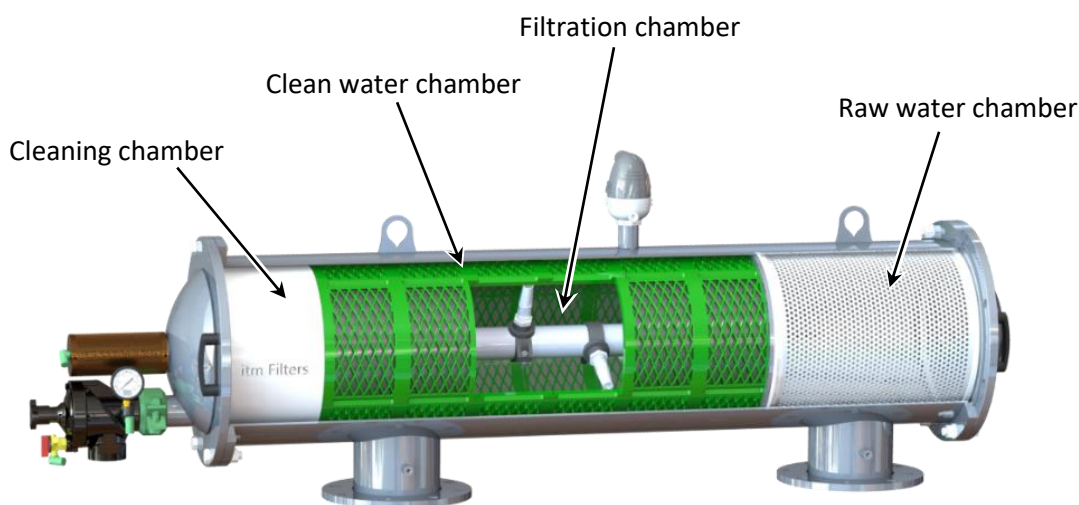

IMAGE 5

6. MAINTENANCE AND SPARE PARTS

6.1 Maintenance

- Gasket check.
- Battery check (if applicable).
- The filter mesh requires periodic manual cleaning, for this:
 1. Disconnect the power supply and the water supply.
 2. Open the drain cock in the "CLOSE" position and wait for the filter to drain.
 3. Loosen the screws on the cover of the filtered water outlet area.
 4. Remove the filter cartridge and clean it with water on the outside and a cedar brush on the inside.
 5. Insert the mesh cartridge and close the lid making sure it is tight.

On our website: www.itmfilters.com you can find a video tutorial with the maintenance process.

6.2 Exploded view

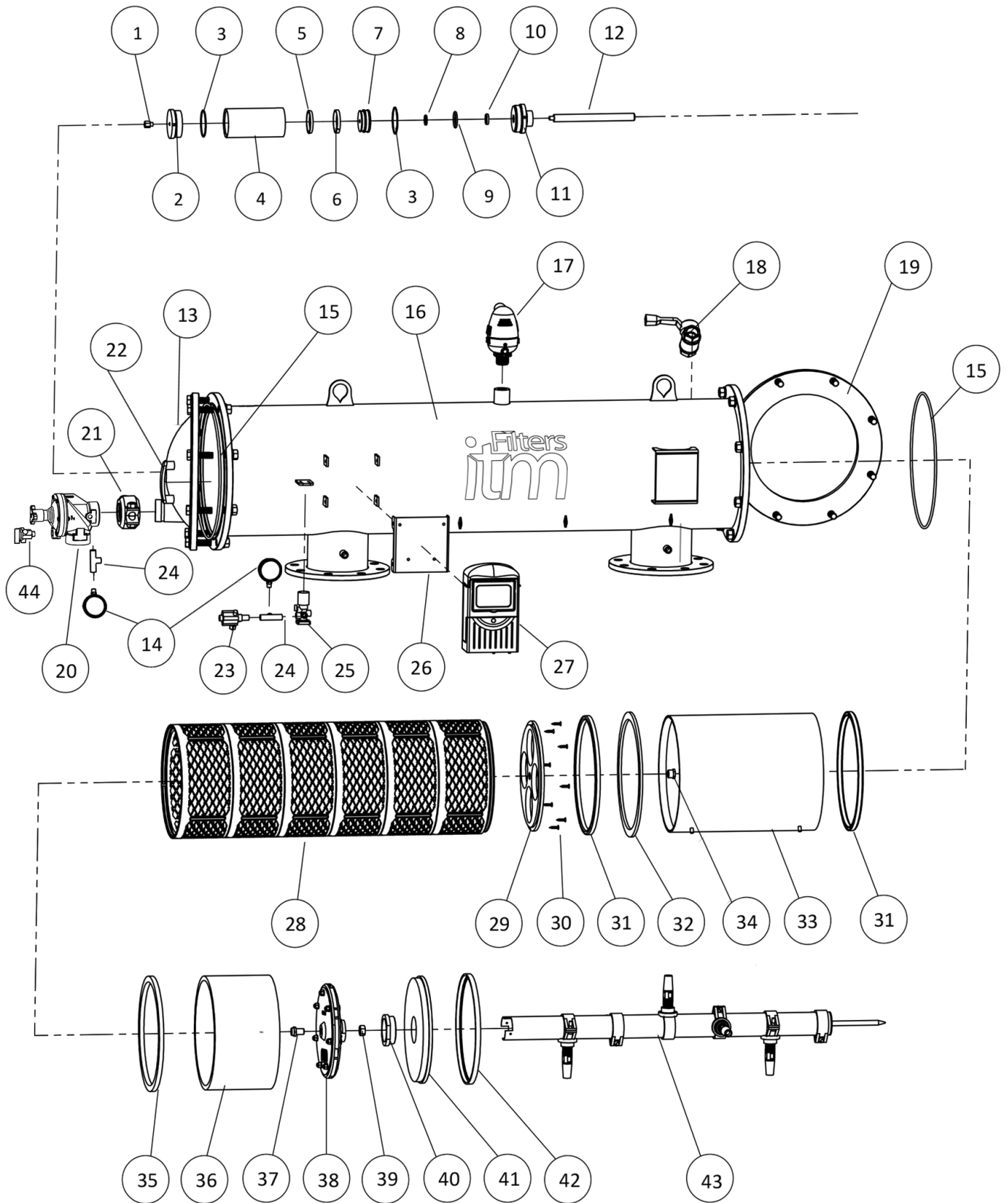

6.3 Exploded view table

Nº	DENOMINATION	HYDRAULIC-200-H-INOX MODELS							
		204-H & 206-H COMP		206-H & 208-H COMP		208-H & 210-H COMP		210-H & 212-H COMP	
		U.	Code	U.	Code	U.	Code	U.	Code
1	Calibrated Orifice	1	HYD-206-H-06-06	1	HYD-206-H-06-06	1	HYD-206-H-06-06	1	HYD-206-H-06-06
2	Calibrated Orifice Cap	1	HYD-206-H-06-03	1	HYD-206-H-06-03	1	HYD-206-H-06-03	1	HYD-206-H-06-03
3	Gasket 1	2	-	2	-	2	-	2	-
4	Cylinder Liner	1	HYD-206-H-06-04	1	HYD-206-H-06-04	1	HYD-206-H-06-04	1	HYD-206-H-06-04
5	Piston Guide Ring	1	-	1	-	1	-	1	-
6	Gasket 2	1	-	1	-	1	-	1	-
7	Piston Cap	1	HYD-206-H-06-04	1	HYD-206-H-06-04	1	HYD-206-H-06-04	1	HYD-206-H-06-04
8	Gasket 3	1	-	1	-	1	-	1	-
9	Gasket 4	1	-	1	-	1	-	1	-
10	Gasket 5	1	-	1	-	1	-	1	-
11	Cylinder Cap	1	HYD-206-H-06-02	1	HYD-206-H-06-02	1	HYD-206-H-06-02	1	HYD-206-H-06-02
12	Stem	1	HYD-206-H-06-01	1	HYD-206-H-06-01	1	HYD-206-H-06-01	1	HYD-206-H-06-01
13	Cylinder Side Cap	1	HYD-206-H-08-00	1	HYD-206-H-08-00	1	HYD-206-H-08-00	1	HYD-206-H-08-00
14	Pressure Gauge	2	-	2	-	2	-	2	-
15	Gasket 6	1	-	1	-	1	-	1	-
16	Casing	1	HYD-204/6-H-02	1	HYD-206-H-02	1	HYD-208-H-02	1	HYD-210-H-02
17	Air Valve 1"	1	-	1	-	1	-	1	-
18	Ball Valve 2"	1	-	1	-	1	-	1	-
19	Grinding Side Cap	1	HYD-206-H-07-00	1	HYD-206-H-07-00	1	HYD-206-H-07-00	1	HYD-206-H-07-00
20	Valve 2"	1	-	1	-	1	-	1	-
21	Victaulic Clamp 2"	1	-	1	-	1	-	1	-
22	Black handle	2	-	2	-	2	-	2	-
23	Hydraulic relay	1	-	1	-	1	-	1	-
24	Steel T Fitting	1	-	1	-	1	-	1	-
25	Solenoid	1	-	1	-	1	-	1	-
26	Electrical panel support	1	HYD-206-H-02-06	1	HYD-206-H-02-06	1	HYD-206-02-06	1	HYD-206-H-02-06
27	Programmer	1	-	1	-	1	-	1	-
28	Filter Cartridge	1	HYD-204-H-04-00	1	HYD-206-H-04-00	1	HYD-208-H-04-00	1	HYD-210-H-04-00
29	Centering Disk	1	HYD-206-H-05-07	1	HYD-206-H-05-07	1	HYD-206-H-05-07	1	HYD-206-H-05-07
30	PVC Screw	8	-	8	-	8	-	8	-
31	Grinding Gasket Cartridge	2	HYD-206-H-03-04	2	HYD-206-H-03-04	2	HYD-206-H-03-04	2	HYD-206-H-03-04
32	Gasket between Cartridges	1	HYD-206-H-05-06	1	HYD-206-H-05-06	1	HYD-206-H-05-06	1	HYD-206-H-05-06
33	Grinding Cartridge	1	HYD-206-H-03-00	1	HYD-206-H-03-00	1	HYD-206-H-03-00	1	HYD-206-H-03-00
34	Stainless bushing	1	HYD-206-H-05-08	1	HYD-206-H-05-08	1	HYD-206-H-05-08	1	HYD-206-H-05-08
35	Squared Gasket	1	HYD-206-H-07-04	1	HYD-206-H-07-04	1	HYD-206-H-07-04	1	HYD-206-H-07-04
36	PVC Pipe	1	HYD-206-H-05-04	1	HYD-206-H-05-04	1	HYD-206-H-05-04	1	HYD-206-H-05-04
37	Turning screw	1	HYD-206-H-05-1-4	1	HYD-206-H-05-1-4	1	HYD-206-H-05-1-4	1	HYD-206-H-05-1-4
38	Turbine cap	1	HYD-206-H-05-1-2	1	HYD-206-H-05-1-2	1	HYD-206-H-05-1-2	1	HYD-206-H-05-1-2
39	Hex nut	1	-	1	-	1	-	1	-
40	Guide Bushing	1	HYD-206-H-05-10	1	HYD-206-H-05-10	1	HYD-206-H-05-10	1	HYD-206-H-05-10
41	Cleaning Chamber Disk	1	HYD-206-H-05-02	1	HYD-206-H-05-02	1	HYD-206-H-05-02	1	HYD-206-H-05-02
42	Gasket Disk C.L.	1	HYD-206-H-05-2-2	1	HYD-206-H-05-2-2	1	-	1	-
43	Scanner	1	HYD-204-H-05-00	1	HYD-206-H-05-00	1	HYD-208-H-05-00	1	HYD-210-H-05-00
44	4-way 3-position tap	1	-	1	-	1	-	1	-

TABLE 5

*Screws for the cylinder side cap (nº13) and grinding side cap (nº19)

- Closing hardware:
 - Hexagonal screw M16x60. 16 U.
 - Hexagonal nut M16. 16 U.
 - Flat washer D16. 32 U.
- Hinge hardware:
 - Hexagonal screw M16x60. 4 U.
 - Nylon washer M10. 8 U.
 - Brake nut M10.

7. CONTROL PANEL

NOTE: All our filters have the control panel configured according to standard specifications.

7.1 Features listing

- The “FILTRON 1-10” is a modular type backwash controller for automatic filters from 1 to 10 stations.
- Models for direct current (DC) and alternating current (AC) are available.
- The DC model can be powered by either 6v DC or 12v DC and activates 12v DC 2-wire latch-type solenoids. The voltage for solenoid switching is supplied by a charge pump.
- The AC model contains an internal transformer that can be powered by 110V or 220V from which 24v AC is generated for the solenoids.
- The wash cycles can be triggered either by time or by means of the electronic PD sensor when it reaches the preset value, or by a dry contact signal from an external type PD sensor.
- Looping problems can be eliminated by detecting repeated consecutive cycles that exceed the predefined value.
- The unit can optionally handle a Pressure Sustaining valve, and an Alarm output.
- The unit is equipped with a custom LCD screen and keypad.
- The unit counts separately the number of washing cycles triggered by DP, by time or manually.



7.2 How to program the controller

The controller is equipped with an LCD display and 4 keys as shown below. When the unit is not touched for one minute the display turns off and the only sign of life is given by a beep sound that can be heard every 20 seconds. Pressing any of the keys for a few seconds will bring the display back on.

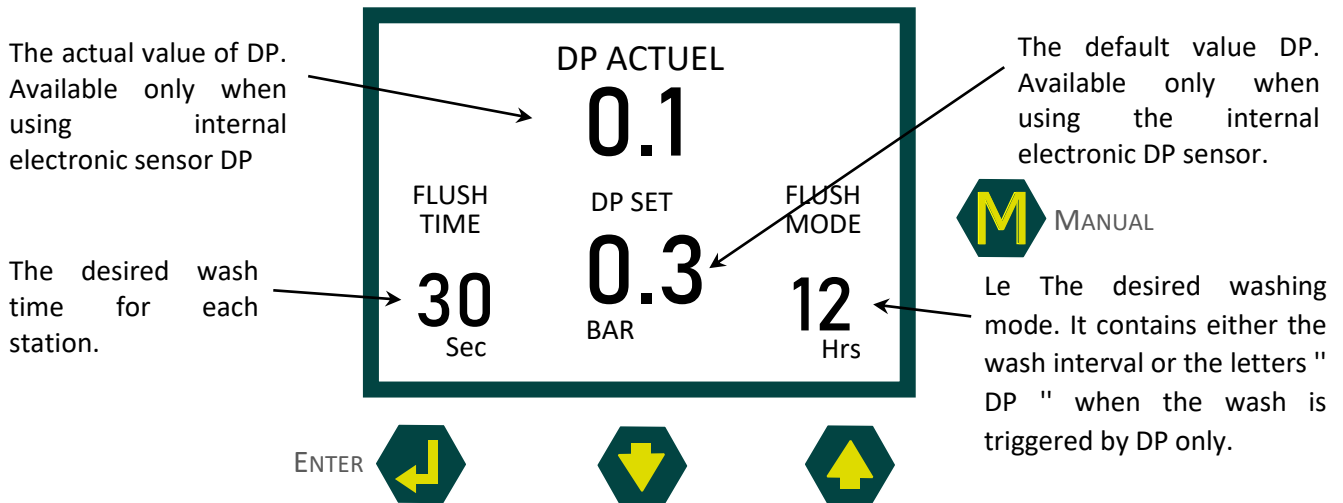

The screen contains several fields, some of them are editable and some of them are not. To insert the EDIT MODE, press the ENTER key. The EDIT MODE is indicated by the flashing of the characters in the corresponding editable field. Each time the ENTER key is pressed the next editable field will come into focus and begin to flash. In EDIT MODE the "+" and "-" keys are used to change the value of the field under focus. If the ENTER key is pressed again the selected value will be fixed and the focus will move to the next editable field which will begin to flash. Once this key editing mode is entered, the user will not be able to go back and must keep pressing the ENTER key repeatedly, to go through the chain of editable fields until reaching the WASH TIME field again.

* Please note that before the first use of the unit, it may be necessary to go through the configuration process before defining the wash program in order to adjust the characteristics of the controller for a specific use. The setup process is described below.

7.3 The chain of editable fields

The editable field sequence is shown below. The existence of the DP DEFAULT field depends on whether the system has the DP sensor included or not.

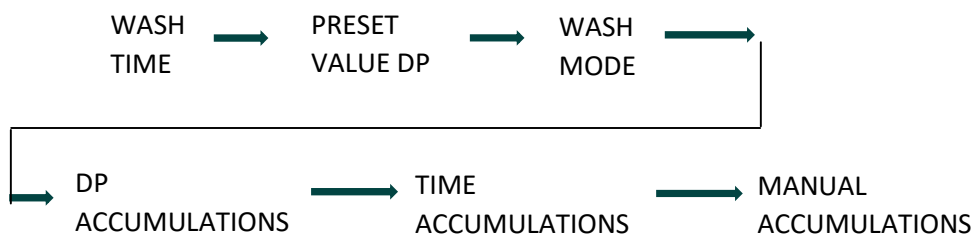

7.4 Wash time

Defines the duration of the wash time per station. The following options can be selected:

- 5-20 seconds in 1 second intervals
- 20-55 seconds in 5-second intervals
- 1-6 minutes in 0,5 minute intervals

7.5 DP preset value

In this field the user defines the value of the pressure difference between the inlet and outlet of the filter that, when reached, will cause the beginning of the wash cycle. This field appears only when the system includes the electronic DP sensor.

When pressure is expressed in BAR, the range of values is 0.1 - 2.0 BAR. When pressure is expressed in PSI the range of values is 1-30 PSI.

When the system does not include the electronic PD sensor. but an external PD sensor is connected, the flush request signal comes in the form of dry contact.

7.6 Wash mode

The wash mode defines how the wash cycles will be triggered. The options are as follows:

- **OFF** - There will be no washing
- **By time** - In this case the wash cycles will be repeated at a selected interval or triggered by the DP signal depending on which occurs first. No matter how the wash cycle started, the interval to the next cycle will start to be measured again after each end of the wash sequence. The selection ranges are as follows:
 - 5, 10, 15, 20, 25, 30, 35, 40, 45, 50, 55, 60 minutes
 - 2, 3, 4, 5, 6, 8, 12, 18, 24, 72, 120 hours
- **DP** - the wash will be triggered by DP only.
 - 5, 10, 15, 20, 25, 30, 35, 40, 45, 50, 55, 60 minutes
 - 2, 3, 4, 5, 6, 8, 12, 18, 24, 72, 120 hours
- **DP** - the wash will be triggered by DP only.

* If the "+" and "-" keys are pressed and held simultaneously, the "Wash Mode" field will show the time remaining until the next cycle, alternatively, first hours and then minutes.

7.7 Accumulations

The unit accumulates and displays the number of wash cycles caused by DP, by time, or manually. In each of the accumulation fields, the "+" or "-" keys can be used to clear the accumulated value.

7.8 Setup

In order to enter the configuration process, press and hold the ENTER key for 3 seconds. The unit will detect how many “plug in” boards (each with 2 outputs) are used in the particular case. The assignment of the outputs depends on the definitions made during the configuration process. During the configuration process, the following characteristics are defined:

Main valve - (Sustaining valve)	Yes / No. When the answer is “Yes” you can define the Pre delay. Wait between the opening of the main valve and the opening of Station No. 1 The selectable delay intervals are as follows: 5, 10, 15, 20, 25, 30, 35, 40, 45, 50, 55 seconds 1, 1.5, 2, 2.5, 3, 3.5, 4, 4.5, 5, 5.5, 6 minutes
Waiting time -	The delay between stations - 5, 10, 15, 20, 25, 30, 35, 40, 45, 50, 55, 60 seconds.
DP delay -	The delay that the DP sensor reading is expected to be stable before reacting - 5, 10, 15, 20, 25, 30, 35, 40, 45, 50, 55, 60 seconds.
Loop limit -	The number of consecutive wash cycles triggered by the DP sensor before deciding that there is a no-end-of-loop problem. The options are: 1-10 or "no" which means to ignore the loop problem.
Alarm -	Yes / No - assigning an output for alarm activation.
Delay Valve -	Yes / No - assigning an output for Delay Valve activation.
See outputs -	This is a special mode that allows you to review the list of outputs to see how each of the outputs is assigned. Use the + key to change the “no” to a “yes” and confirm with “Enter”, then use the + key to scroll through the list. The output number is displayed in the lower left corner and its assigned role appears in large letters in the center of the screen. Note that the number of possible outputs that can be used is always an even number since it results from the number of plug-in boards included (2 outputs each). However, if the number of outputs required is not an even number, then the last valve assigned as a filter can be canceled by using the manual operations key. 
Pressure units -	To choose the units to be used for pressure measurement. Select between BAR or PSI.
Calibration -	Zero calibration of the integrated electronic DP sensor. If the sensor ports are disconnected select Calibration = Yes.
Version -	The last screen in configuration indicates the version of the controller software. The version is displayed with four digits like the following:

00

13

7.9 Handling endless loop problems

As explained above, an endless loop problem will be declared when the number of consecutive wash cycles triggered by the DP sensor exceeds the “Loop Limit” defined during setup. When an endless loop problem is detected, it will be indicated on the screen (LOOPING) and the alarm output will be activated. In addition, the indication of DP should no longer be taken into account as a trigger for washing. Subsequent wash cycles will only be triggered by a countdown interval. The problem will be considered solved when the constant indication of the DP sensor has been eliminated.

7.10 Handling low pressure

When an indication of closed contact is received at the controller's low pressure input, the symbol  will begin to appear flashing on the display. All activities will stop including the countdown to the next wash cycle. If there is low pressure while a flush sequence is in progress, when the low pressure condition ends, the flush sequence will start from the beginning instead of continuing from the stop point.

7.11 Connecting the DP sensor to the filter system

The DP sensor is connected to the filter system by 2 command tubes, one that comes from the filter inlet (high pressure) will be connected to the red point, and the one that comes from the outlet (low pressure) will go towards the black point. It is important to install a small 120 mesh filter (not provided) between the red dot and the high pressure connection point.

The small filter to be added between the high pressure inlet and the red dot. **It is the user's responsibility to add this filter**

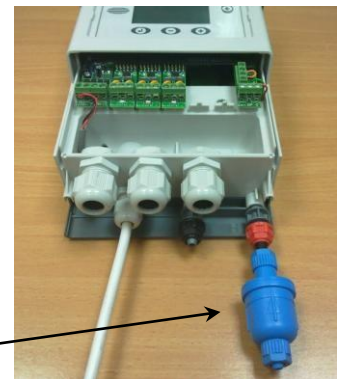

7.12 Low battery

The unit has two levels of low battery indication. The first level is when the battery voltage drops to the first level, the sign  will start to appear on the screen. When the battery voltage continues to drop and reaches the second level, all outputs will close, the screen will clear displaying only the low battery icon.

7.13 Manual activation

The wash sequence can be activated manually by using the “MANUAL” key. When activated manually, the icon  will appear on the screen. The same key will be used to manually end the sequence in progress.

7.14 Timing diagram

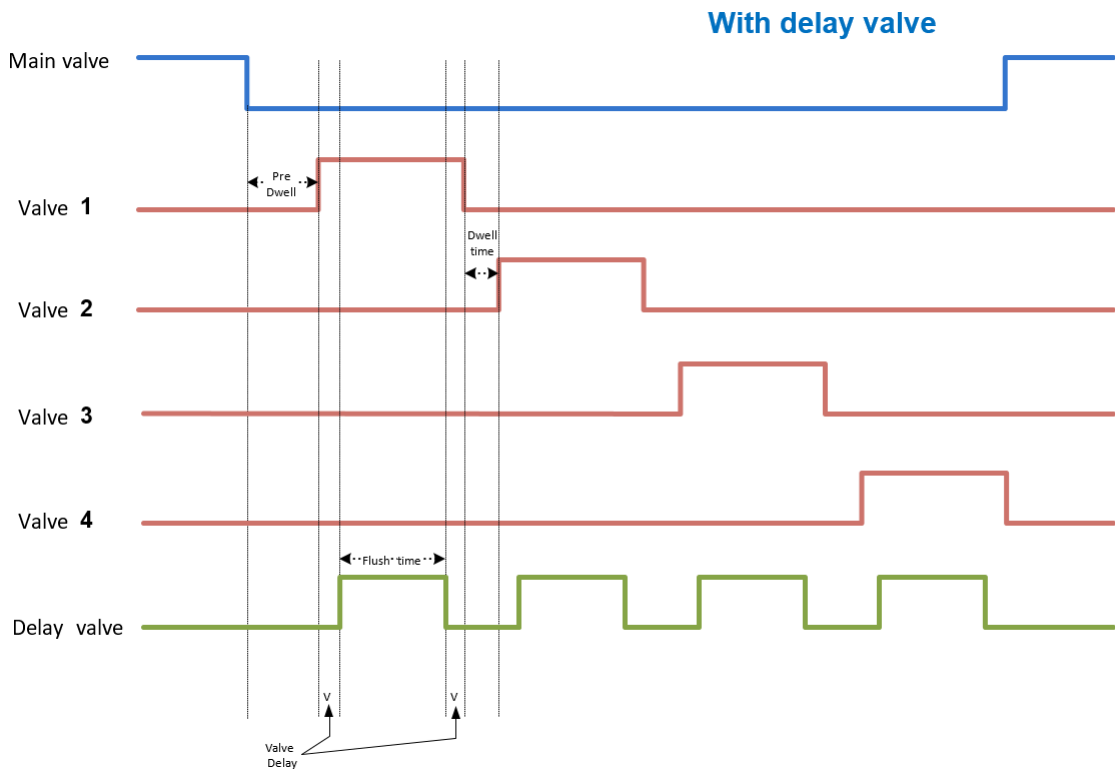
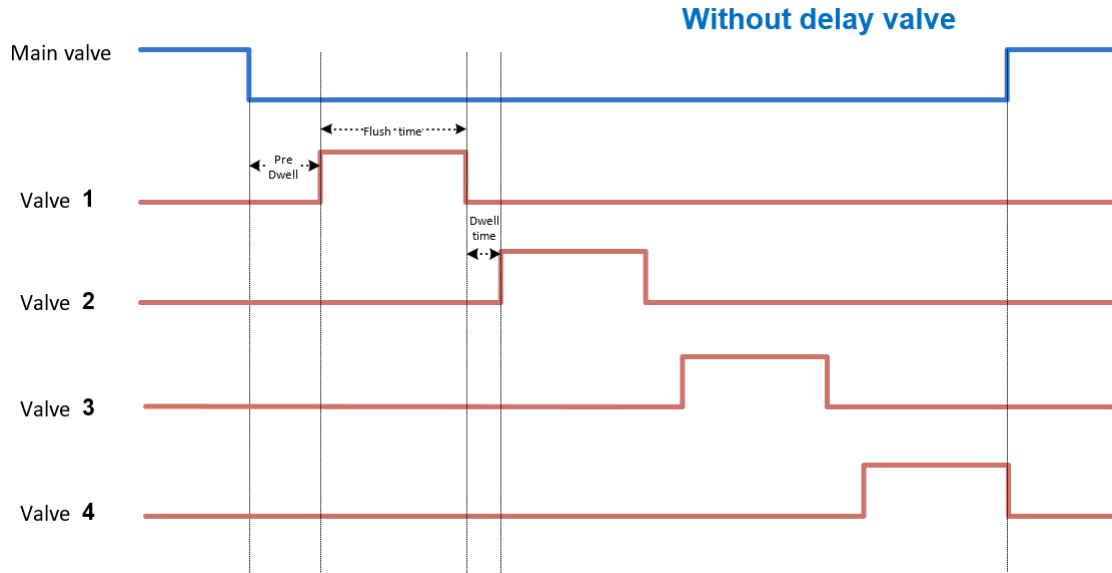

7.15 Wiring diagram

- DC model

The following diagram shows the wiring for the DC controller model.

Note that:

1. The external DP sensor is optional and is intended to be used in cases where the integrated electronic DP sensor is not included.
2. The unit can be powered by 6v DC or 12v DC.
3. The solenoids are 12v DC latch type.

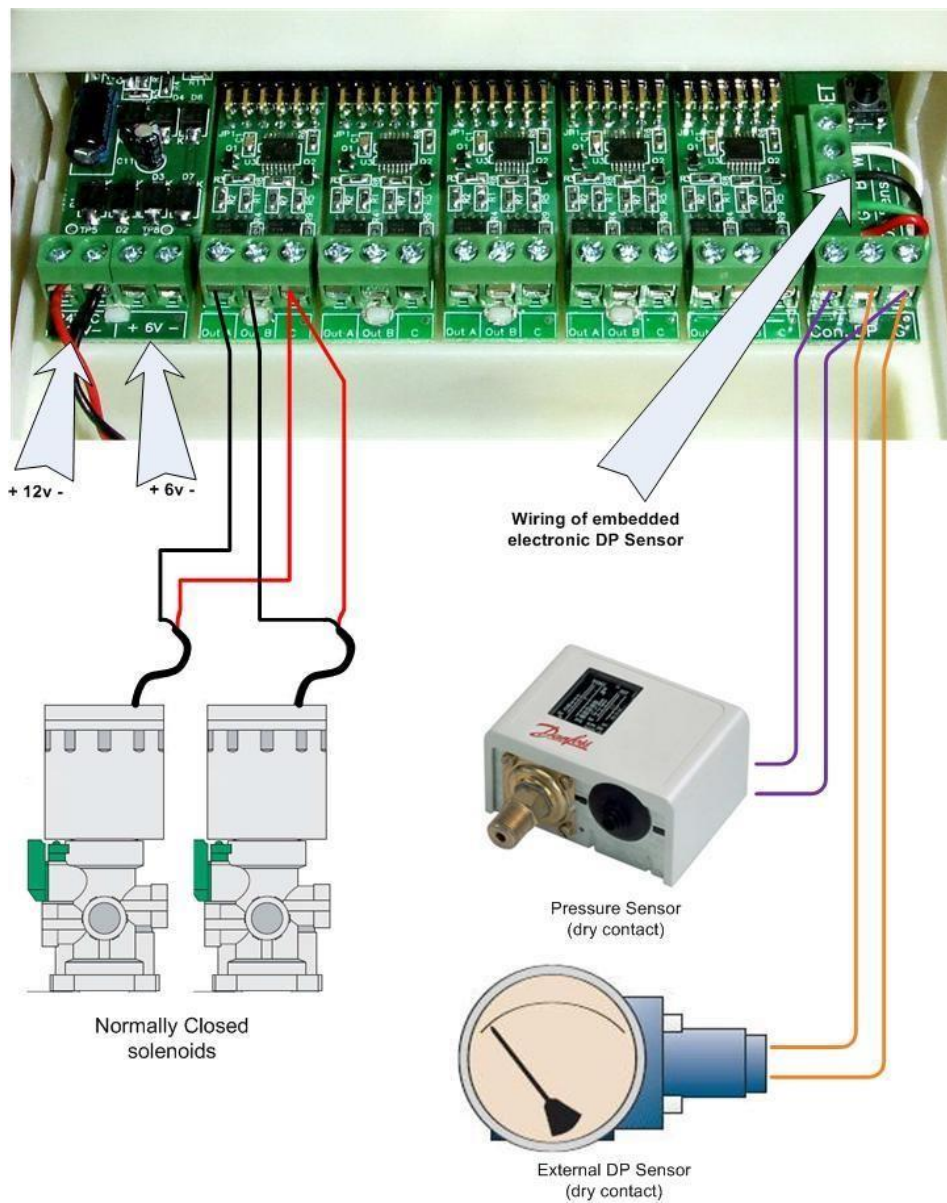

* Be sure to turn off the power before inserting/removing the 2-output cards (Plug in)

- AC model

The following diagram shows the wiring for the AC controller model.

Note that:

1. The external PD sensor is optional and is intended to be used in cases where the integrated electronic PD sensor is not included.
2. The unit is powered by 24v AC transformed from 220/110 v AC.
3. In the solenoids it will be 24v AC.

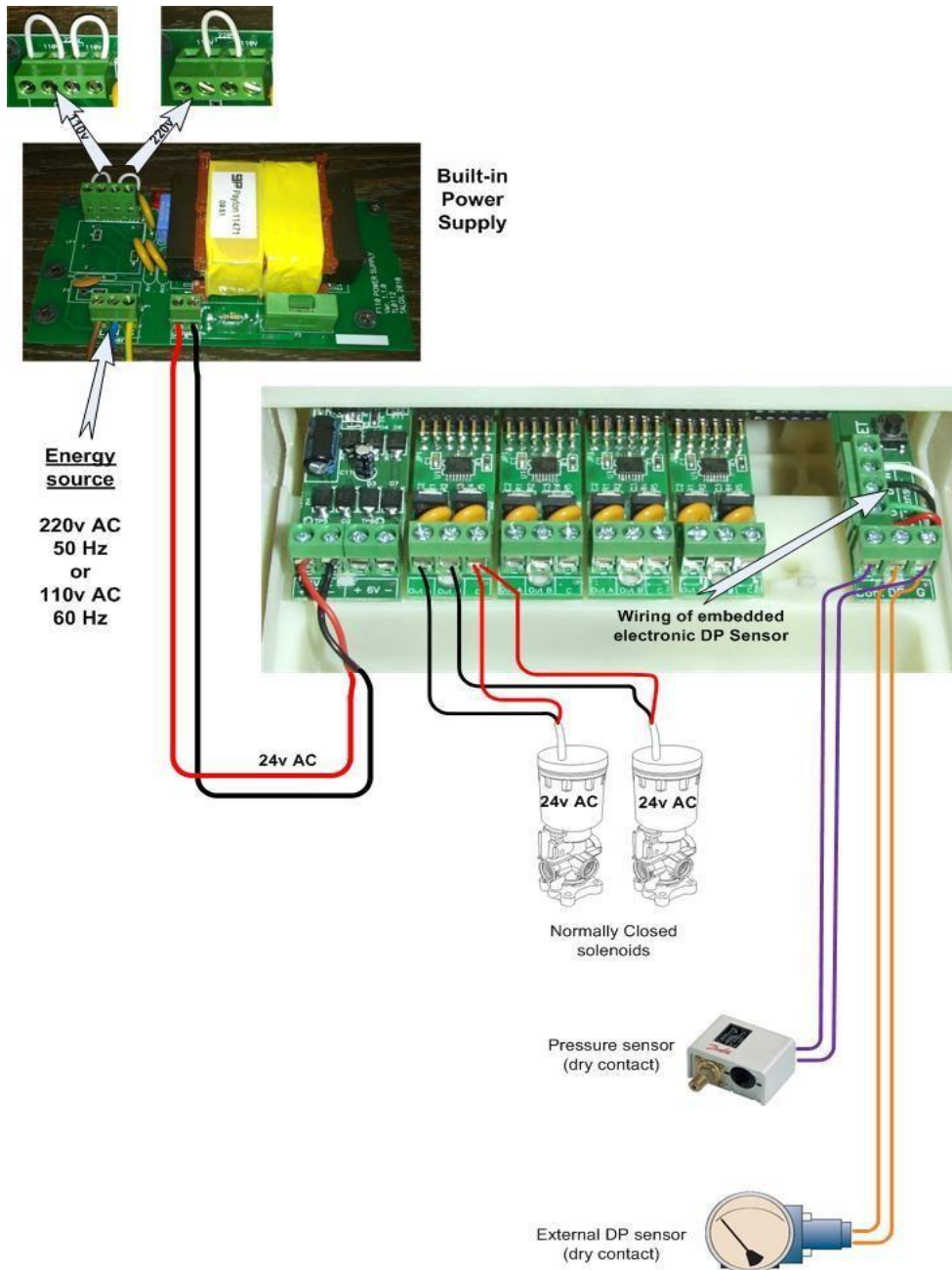

* Be sure to turn off the power before inserting/removing the 2-output cards (Plug in)

7.16 Technical data

- **DC model**

Power source :	6v supplied by 4 alkaline batteries size 1.5 "D". or a 12v DC dry battery or a 12v rechargeable battery with a 2 watt solar panel
Output :	12v DC latch solenoids.
DP :	Integrated analog electronic DP sensor or external dry contact DP sensor.
Pressure sensor :	Dry contact pressure sensor
Operating temperature :	0-60 °C.

- **AC model**

Power source :	220 or 110 v AC 50 or 60 Hz with included transformer to 24v AC.
Output:	24v AC solenoids
DP :	Integrated analog electronic DP sensor or external dry contact DP sensor.
Pressure sensor :	Dry contact pressure sensor
Operating temperature :	0-60 °C.

8. PRODUCT WARRANTY

1. All ITM FILTERS products are guaranteed for 1 year from the date of invoice.
2. The replacement of defective parts is covered by the warranty, being necessary to indicate the serial number and allow the verification by our staff.
3. Take into account the user manual for the installation of the product and check the operating parameters in the technical tables.
4. To obtain a correct filtration, the size of the filter element must be smaller than that of the substances suspended in the water to be filtered.
5. This warranty will not apply in the event of damage or defects produced in the product as a result of or related to:
 - i. Tearing, elimination or manipulation of the identifying label of the product.
 - ii. Improper or unauthorized use of the product by the buyer.
 - iii. An improper assembly or installation that does not correspond to that established by ITM FILTERS.
 - iv. The pertinent periodic cleanings.
 - v. The use of water that does not meet the established quality or is outside the specifications indicated in the technical tables.
 - vi. A use of flow discordant with the water quality according to the parameters defined in the technical tables.
 - vii. Pressures that differ from the established working pressure.
 - viii. The wear of materials caused by fatigue, abrasion or high temperatures.
 - ix. Moisture in electrical components.
 - x. Electrical voltages that differ from those established in the electrical panel.
 - xi. Any external alteration, modification or repair of the products, except by ITM FILTERS and its technical representatives.
 - xii. Damages produced during the transport of the product.
 - xiii. Third party damage, theft or vandalism.
6. At ITM FILTERS we are committed to quality, which is why we have the ISO 9001, ISO 14001 and ISO 45001 certifications. In addition, during the manufacture of our filters we have established our own quality control in which we ensure that the product meets all quality requirements optimally. If you notice any defects, please contact your dealer.
7. For any claim, it is essential to present this document, the serial code of the corresponding product and the purchase invoice.



INTRAMESA MZ S.A.



Polígono Armentera P-99

22400 Monzón (Huesca)

www.itmfilters.com

info@itmfilters.com

Tel. 974 10 50 05