



USER MANUAL

SELF-CLEANING MESH FILTER ELECTRIC-400-H-INOX

Serial number: _____

Purchase date: _____



INDEX

1.	INTRODUCTION	1
1.1	Filter identification	1
1.2	Basic concepts	1
2.	DATA SHEET	2
2.1	Mesh filter ELECTRIC-400-H-INOX.....	2
2.2	Dimensions	3
2.3	Hydraulic & Electric circuit - ELECTRIC-400-H-INOX.....	4
3.	INSTALLATION	5
4.	OPERATION	5
5.	MAINTENANCE AND SPARE PARTS	6
5.1	Maintenance	6
5.2	Exploded view	6
5.3	Exploded view table	8
6.	QUALITY CONTROL.....	9
7.	CONTROL PANEL.....	10
7.1	Equip Characteristics	10
7.2	Program Start	10
7.3	String of editable fields	11
7.4	Alarms.....	14
7.5	Remote communication.....	15
8.	ELECTRICAL DIAGRAM.....	16
9.	PRODUCT WARRANTY	28

1. INTRODUCTION

First of all, we want to thank you for purchasing this filter, the result of the work of a group of people committed to offering the correct solution to each filtration process. All products designed and manufactured by ITM Filters meet self-imposed requirements for quality, efficiency and durability. This philosophy is accredited through certification by external bodies.

The highest efficiency of the system is obtained with correct operation and maintenance, please properly follow the indications in this manual throughout the life of the product. We invite you to visit our website: www.itmfilters.com for more information about our products and our company policies.

1.1 Filter identification

The filter is identified with the following nameplate:

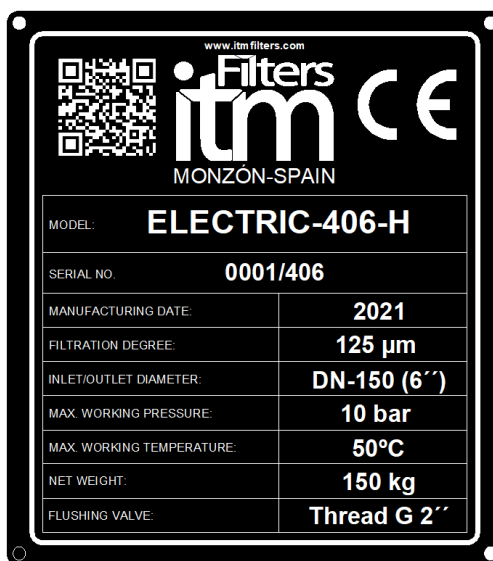

IMAGE 1

1.2 Basic concepts

Filtration surface: Area that allows water to pass while retaining suspended particles.

Recommended flow: Optimal filtration must take into account the quality of the source water and its use. The quality of the source water is divided into 4 sections, which have maximum theoretical flows. The sectorization corresponds to the particles per million in the water.

0. Stretch 1: 0-50ppm.
1. Stretch 2: 50-100ppm
2. Stretch 3: 100/200ppm.
3. Stretch 4: > 200ppm.

Loss of pressure (HEAD LOSS): It is the difference in load produced between two points of the same flow. The friction of the water with the filter medium produces a loss of energy. The substances are trapped in the mesh generating a decrease in the porosity of the filter medium, which causes an increase in the pressure drop. The pressure drop measurement is carried out by means of a pressure tap on the inlet manifold and another one on the outlet manifold.

2. DATA SHEET

2.1 Mesh filter ELECTRIC-400-H-INOX



Working pressure
min. 2 kg/cm²
máx. 10 kg/cm²

IMAGE 2

MODEL	Ø1/Ø0	Flow (m3/h)				Filtration Surface (cm ²)	Water Consumption per Wash (l)	Net Weight (kg)
		Máx. Flow	<50ppm	50/100 ppm	100/200 ppm			
ELECTRIC-404-H-INOX	Flange 4"	205	93	76	57	5608	40	139
ELECTRIC-406-H-INOX -COMPACT	Flange 6"	250	133	105	80	5608	40	142
ELECTRIC-406-H-INOX	Flange 6"	275	163	123	92	8412	95	150
ELECTRIC-408-H-INOX -COMPACT	Flange 8"	360	220	160	125	8412	95	153
ELECTRIC-408-H-INOX	Flange 8"	415	253	194	142	11216	155	173
ELECTRIC-410-H-INOX -COMPACT	Flange 10"	510	295	240	123	11216	155	177
ELECTRIC-410-H-INOX	Flange 10"	585	323	273	195	14020	195	187
ELECTRIC-412-H-INOX -COMPACT	Flange 12"	645	355	300	215	14020	195	191

TABLE 1

Manufacturing technical characteristics:

- Materials:
 - Stainless steel metal components.
 - A2 stainless steel screws.
 - Mesh cartridge: Injected plastic structure with AISI-316 Stainless Steel. Filtration degree: 125 microns.
 - Grinding cartridge: AISI-304 Stainless Steel.
 - EPDM gaskets: 60 SHORE.
- Superficial treatment:
 - Surface shot blasting up to SA ½ grade.
- Working characteristics:
 - Maximum operating temperature 50°C.
- Commercial components:
 - 1" Suction Cup and 2" Flushing Valve.
 - Electrical box powered with single phase current 230V 50Hz. *Consult other options.

2.2 Dimensions

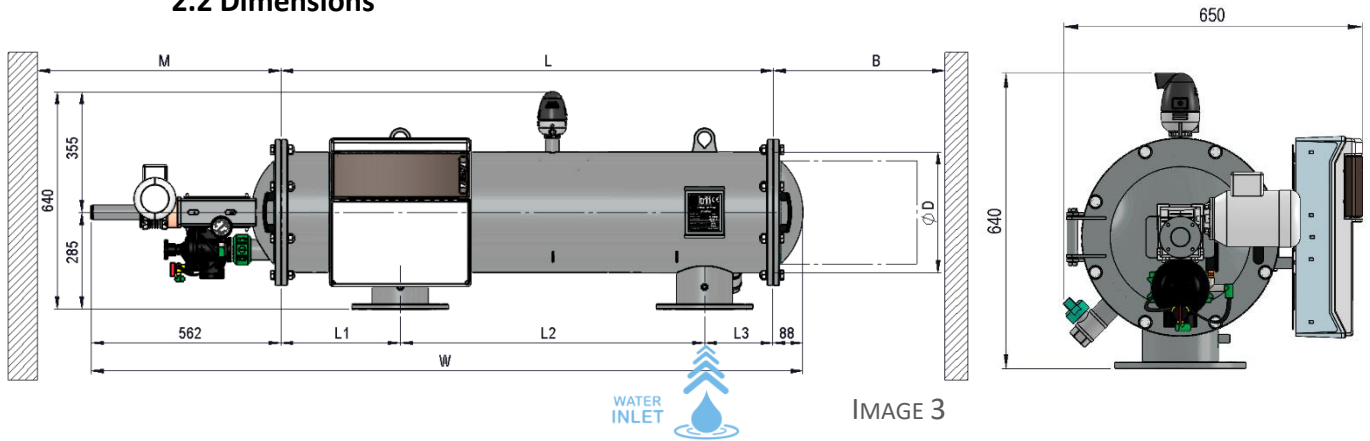

MODEL	Dimensions (mm)							
	ØD	L	L1	L2	L3	W	M	B
ELECTRIC-404-H-INOX	355	1170	197	770	203	1580	650	1015
ELECTRIC-406-H-INOX-COMPACT	355	1170	197	770	203	1580	650	1015
ELECTRIC-406-H-INOX	355	1455	352	900	203	1865	650	1300
ELECTRIC-408-H-INOX-COMPACT	355	1455	352	900	203	1865	650	1300
ELECTRIC-408-H-INOX	355	1741	438	1100	203	2150	650	1585
ELECTRIC-410-H-INOX-COMPACT	355	1741	438	1100	203	2150	650	1585
ELECTRIC-410-H-INOX	355	2027	446	1370	211	2435	650	1870
ELECTRIC-412-H-INOX-COMPACT	355	2027	446	1370	211	2435	650	1870

TABLE 2

MODEL	General Data					
	Minimum Pressure (Bar)	Nozzle Units	ØAuto Flushing Valve	ØManual Exhaust Valve	Washing Time (s)	Motor Power (kW)
ELECTRIC-404-H-INOX	2	4	2"	1-1/2"	20	0,18
ELECTRIC-406-H-INOX-COMPACT	2	4	2"	1-1/2"	20	0,18
ELECTRIC-406-H-INOX	2	6	2"	1-1/2"	20	0,18
ELECTRIC-408-H-INOX-COMPACT	2	6	2"	1-1/2"	20	0,18
ELECTRIC-408-H-INOX	2	8	2"	1-1/2"	20	0,18
ELECTRIC-410-H-INOX-COMPACT	2	8	2"	1-1/2"	20	0,18
ELECTRIC-410-H-INOX	2	10	2"	1-1/2"	20	0,18
ELECTRIC-412-H-INOX-COMPACT	2	10	2"	1-1/2"	20	0,18

TABLE 3

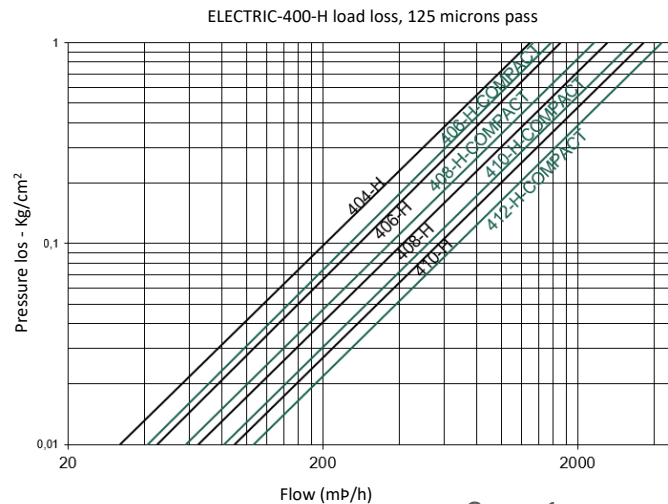

CHART 1

2.3 Hydraulic & Electric circuit - ELECTRIC-400-H-INOX

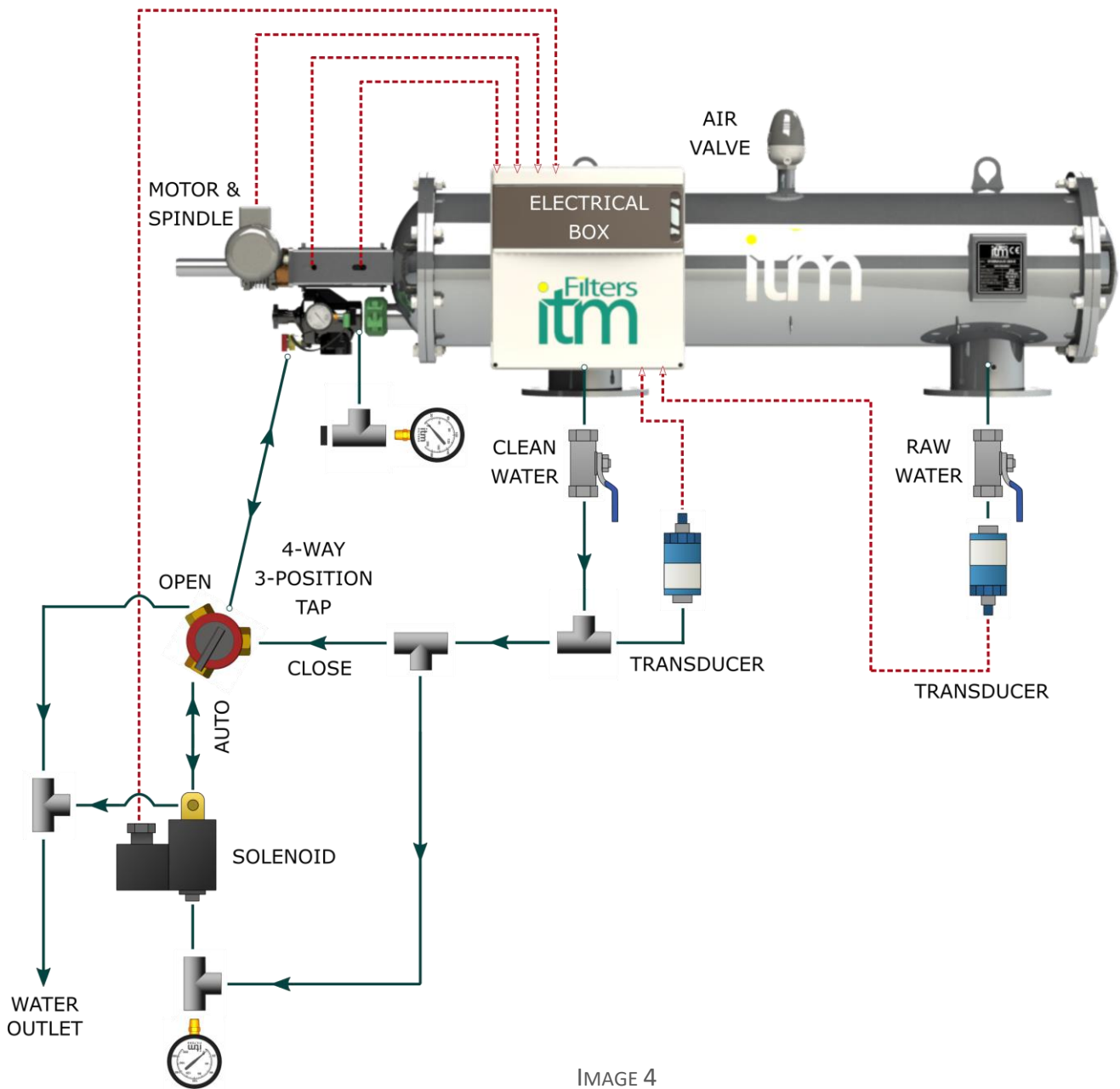

IMAGE 4

* Dashed lines represent an electrical signal: - - - - -
 Continuous lines represent an hydraulic signal: _____

- * The 4-way tap has 3 positions:
- *AUTO* : filter operation with automatic cleaning.
 - *OPEN* : cleaning cycle.
 - *CLOSE* : filter operation (without automatic cleaning)

3. INSTALLATION

1. Place the filter on an accessible flat surface and in the correct flow direction.
2. Position the inlet and outlet manifolds, fixing the flanges with their corresponding gaskets.
3. Check that the drain outlet is directed to the desired area.
4. Check that the unions are tight, turn on the water supply and verify that there is no leak.
5. Filtering. Open the water flow at the recommended flow rate and at a working pressure between 2-10 kg/cm².
6. Cleaning. When the pressure gauge indicates a pressure difference equal to or greater than 0,3 kg/cm², the automatic filter cleaning will begin, without interrupting the water filtering process. The cleaning cycle leaves the factory with a duration of 20 seconds, it must be adjusted during installation as it depends on the working pressure. For the cleaning to be automatic, the key must be in the "AUTO" position.

* Note: Place a check valve at the outlet of the filter, to avoid reverse flows and internal breaks in the filter.

4. OPERATION

Mesh filtering consists of the physical separation between water and the substances that are suspended in it. Water flows from the inside of the filter cartridge to the outside, causing dirt to accumulate on the inside of the filter cartridge.

When the mesh filter becomes clogged, it produces a pressure difference between the inlet and outlet manifolds. The automatic cleaning cycle starts when it reaches a pressure difference of 0.3 kg/cm². To check that the cleaning cycle is correct, it can be started manually pressing the button "S1".

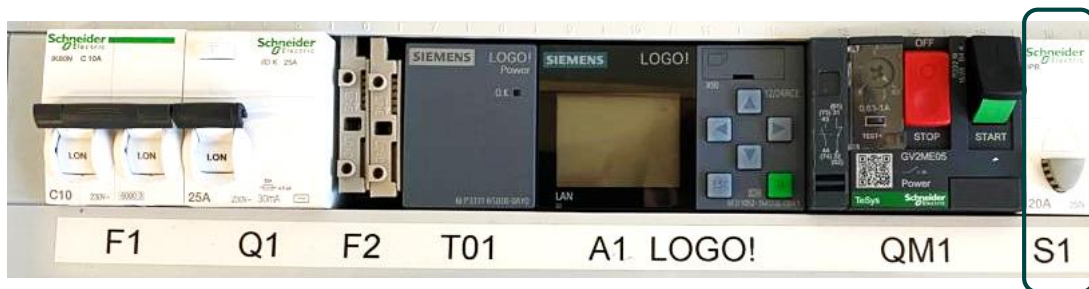

IMAGE 5

Cleaning process. As soon as a pressure difference of 0,3 is reached or when 12 hours of operation have elapsed, the programmer sends the cleaning activation signal. The signal is sent to the solenoid and the motor. The solenoid triggers the hydraulic control system, opens the flushing valve. At the same time, the motor operates the spindle which causes the rotation and translation movements of the scanner.

The pressure difference that occurs between the cleaning chamber (chamber which is communicates with the nozzles through the scanner) and the clean water chamber, along with the Venturi Effect as a result of the geometry of the nozzles, causes the cleaning of the mesh.

The pressure difference between the cleaning chamber and the clean water chamber must not exceed 2 kg/cm². This pressure difference is read during the cleaning process, by subtracting between the two filter pressure gauges.

A higher pressure difference can lead to deterioration of the filter cartridge. To regulate the pressure difference, the cleaning valve must be adjusted through a regulating screw.

The technology used in the manufacture of the ELECTRIC-400-H-INOX filter offers high filtration surfaces with compact lengths, due to the maximization of the filter cartridge.

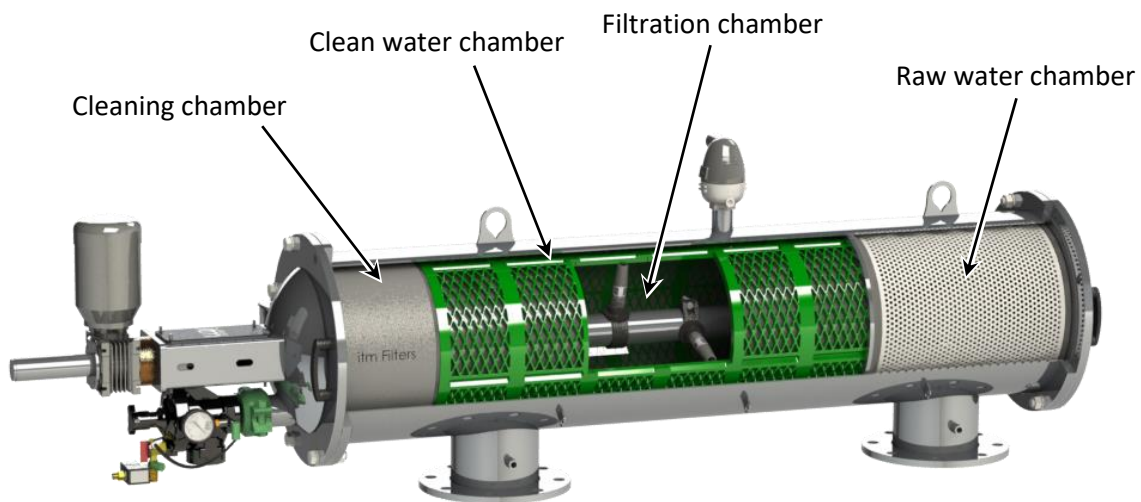

IMAGE 6

5. MAINTENANCE AND SPARE PARTS

5.1 Maintenance

- Gasket check.
- Grease the scanner drive spindle.
- The filter mesh requires periodic manual cleaning, for this:
 1. Disconnect the power supply and the water supply.
 2. Open the drain cock in the "CLOSE" position and wait for the filter to drain.
 3. Loosen the screws on the cover of the filtered water outlet area.
 4. Remove the filter cartridge and clean it with water on the outside and a cedar brush on the inside.
 5. Insert the mesh cartridge and close the lid making sure it is tight.

On our website: www.itmfilters.com you can find a video tutorial with the maintenance process.

5.2 Exploded view

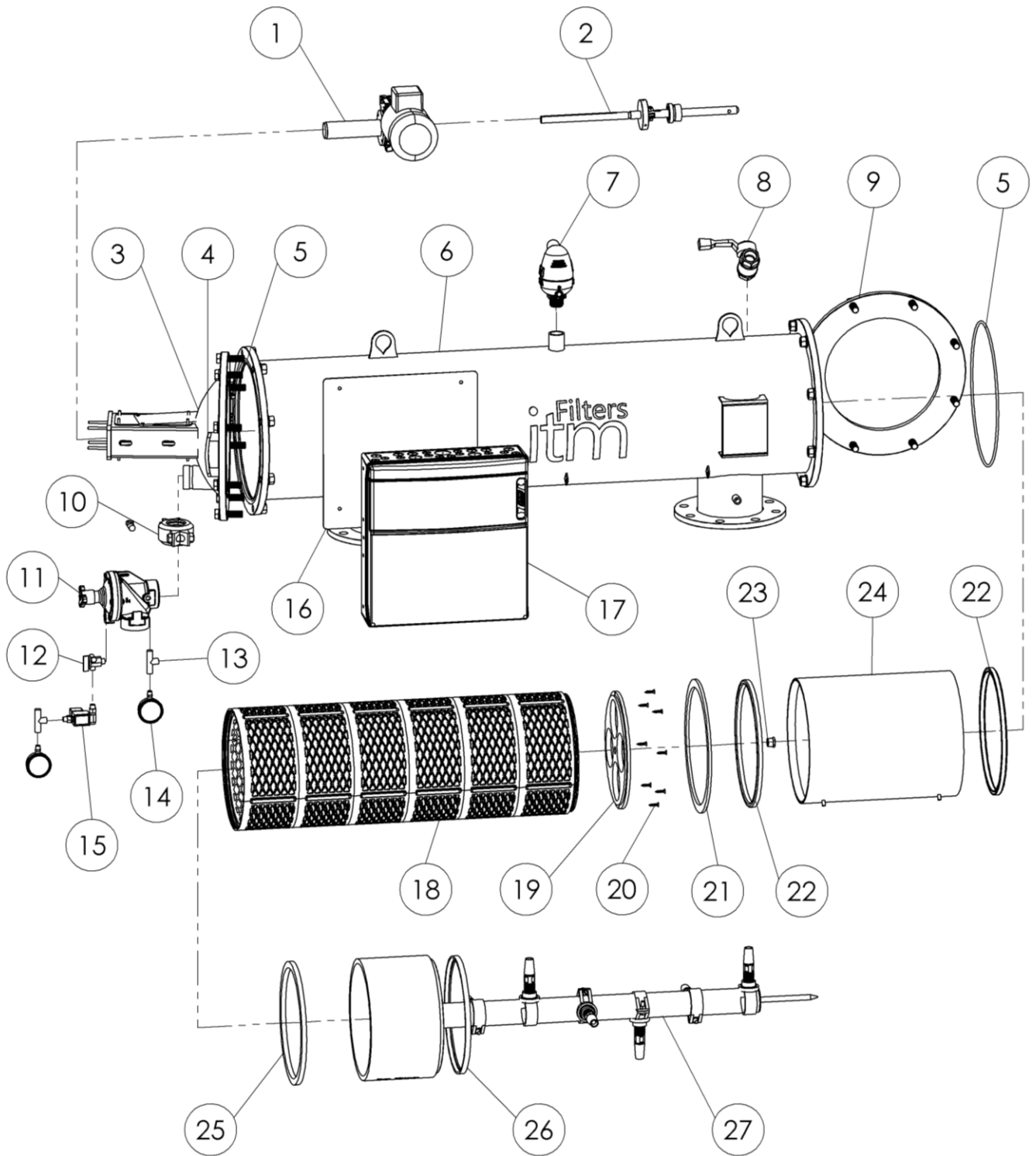

5.3 Exploded view table

Nº	DENOMINATION	ELECTRIC-400-H-INOX MODELS							
		404-H & 406-H-COMP		406-H & 408-H-COMP		408-H & 410-H-COMP		410-H & 412-H COMP	
		U.	Code	U.	Code	U.	Code	U.	Code
1	Electrical Motor	1	-	1	-	1	-	1	-
2	Spindle	1	ELEC-406-H-10-00	1	ELEC-406-H-10-00	1	ELEC-406-H-10-00	1	ELEC-406-H-10-00
3	Spindle Side Cap	1	ELEC-406-H-07-00	1	ELEC-406-H-07-00	1	ELEC-406-H-07-00	1	ELEC-406-H-07-00
4	Black handle	2	-	2	-	2	-	2	-
5	Gasket 6	1	-	1	-	1	-	1	-
6	Casing	1	ELEC-404-H-02	1	ELEC-406-H-02	1	ELEC-408-H-02	1	ELEC-410-H-02
7	Air Valve 1"	1	-	1	-	1	-	1	-
8	Ball Valve 2"	1	-	1	-	1	-	1	-
9	Grinding Side Cap	1	HYD-206-H-08-00	1	HYD-206-H-08-00	1	HYD-206-H-08-00	1	HYD-206-H-08-00
10	Victaulic Clamp 2"	1	-	1	-	1	-	1	-
11	Valve 2"	1	-	1	-	1	-	1	-
12	4-way 3-position tap	1	-	1	-	1	-	1	-
13	Steel T Fitting	2	-	2	-	2	-	2	-
14	Pressure Gauge	2	-	2	-	2	-	2	-
15	Solenoid	1	-	1	1	-	1	-	1
16	Electrical Box Support	1	ELEC-406-H-02-06	1	ELEC-406-H-02-06	1	ELEC-406-02-06	1	ELEC-406-H-02-06
17	Electrical Box	1	-	1	-	1	-	1	-
18	Filter Cartridge	1	ELEC-404-H-04-00	1	ELEC-408-H-04-00	1	ELEC-410-H-04-00	1	ELEC-412-H-04-00
19	Centering Disk	1	HYD-206-H-05-07	1	HYD-206-H-05-07	1	HYD-206-H-05-07	1	HYD-206-H-05-07
20	PVC Screw	8	-	8	-	8	-	8	-
21	Grinding Gasket Cartridge	2	HYD-206-H-03-04	2	HYD-206-H-03-04	2	HYD-206-H-03-04	2	HYD-206-H-03-04
22	Gasket between Cartridges	1	HYD-206-H-05-06	1	HYD-206-H-05-06	1	HYD-206-H-05-06	1	HYD-206-H-05-06
23	Stainless bushing	1	HYD-206-H-03-00	1	HYD-206-H-03-00	1	HYD-206-H-03-00	1	HYD-206-H-03-00
24	Grinding Cartridge	1	HYD-206-H-05-08	1	HYD-206-H-05-08	1	HYD-206-H-05-08	1	HYD-206-H-05-08
25	Squared Gasket	1	HYD-206-H-07-04	1	HYD-206-H-07-04	1	HYD-206-H-07-04	1	HYD-206-H-07-04
26	Gasket Disk C.L.	1	HYD-206-H-05-2-2	1	HYD-206-H-05-2-2	1	HYD-206-H-05-2-2	1	HYD-206-H-05-2-2
27	Scanner	1	ELEC-404-H-05-00	1	ELEC-406-H-05-00	1	ELEC-408-H-05-00	1	ELEC-410-H-05-00

TABLE 4

*Screws for the grinding side cap (nº13) and spindle side cap (nº19)

- Closing hardware:
 - Hexagonal screw M16x60. 16 U.
 - Hexagonal nut M16. 16 U.
 - Flat washer D16. 32 U.
- Hinge hardware:
 - Hexagonal screw M16x60. 4 U.
 - Nylon washer M10. 8 U.
 - Brake nut M10.

6. QUALITY CONTROL

The entire manufacturing process has been carried out in accordance with the applicable European Directives: Directive 2006/42 / CE on Machines-Annex IIA, Directive 2014/68 / EU on Pressure Equipment and Directive 2014/35 / EU on Electrical Material.

These quality requirements are accredited through certification by external organizations:

Certificado ES14/16432.04

INTRAMESA MZ, S.A.
Pol. Ind. Armentera, parcela 99
22400 Morzón (Huesca)

ha sido evaluado como parte del sistema de gestión de GRUPO MARCO EMPRESARIAL 2016, S.L.
organización certificada en cumplimiento de los requisitos de

ISO 9001:2015

Para las siguientes actividades:

**Fabricación de Calderería Industrial y Estructuras Metálicas,
Montaje de Instalaciones y Mantenimientos Industriales, destinados para
los Sectores de la Construcción, Agricultura, Ganadería e Industrial.**

emitiendo los siguientes compromisos:

Pol. Ind. Armentera, parcela 99 - 22400 Morzón (Huesca)

Válido desde
18 de septiembre de 2020 hasta 13 de septiembre de 2023.
Edición 2.

El presente documento es parte del certificado nº ES14/16432.
La vigencia de este documento queda supeditada a la de este certificado.

Autorizado por



Dirección de Certificación

SGS INTERNATIONAL CERTIFICATION SERVICES BERKA, S.A.U.
C/Temporales, 23, 29042 Madrid, España.
T 34 91 313 8115 / 34 91 313 8102 - www.sgs.com

Página 1 de 1

Certificado ES14/16431.04

INTRAMESA MZ, S.A.
Pol. Ind. Armentera parcela 99
22400 Morzón (Huesca)

ha sido evaluado como parte del sistema de gestión de GRUPO MARCO EMPRESARIAL 2016, S.L.
organización certificada en cumplimiento de los requisitos de

ISO 14001:2015

Para las siguientes actividades:

**Fabricación de Calderería Industrial y Estructuras Metálicas,
Montaje de Instalaciones y Mantenimientos Industriales, destinados para
los Sectores de la Construcción, Agricultura, Ganadería e Industrial.**

emitiendo los siguientes compromisos:

Pol. Ind. Armentera parcela 99 - 22400 Morzón (Huesca)

Válido desde
18 de septiembre de 2020 hasta 13 de septiembre de 2023.
Edición 2.

El presente documento es parte del Certificado N°ES: 4/16431.
La vigencia de este documento queda supeditada a la de este certificado.

Autorizado por



Dirección de Certificación

SGS INTERNATIONAL CERTIFICATION SERVICES BERKA, S.A.U.
C/Temporales, 23, 29042 Madrid, España.
T 34 91 313 8115 / 34 91 313 8102 - www.sgs.com

Página 1 de 1

Certificado ES14/16121.04

INTRAMESA MZ, S.A.
Pol. Ind. Armentera parcela 99
22400 Morzón (Huesca)

ha sido evaluado como parte del sistema de gestión de GRUPO MARCO EMPRESARIAL 2016, S.L.
organización certificada en cumplimiento de los requisitos de

ISO 45001:2018

Para las siguientes actividades:

**Fabricación de Calderería Industrial y Estructuras
Metálicas, Montaje de Instalaciones y Mantenimientos
Industriales, destinados para los Sectores de la
Construcción, Agricultura, Ganadería e Industrial.**

emitiendo los siguientes compromisos:

Pol. Ind. Armentera parcela 99 - 22400 Morzón (Huesca)

Válido desde
18 de septiembre de 2020 hasta 13 de septiembre de 2023.
Edición 2.

El presente documento es parte del certificado nº ES14/16121.
La vigencia de este documento queda supeditada a la de este certificado.

Autorizado por



Dirección de Certificación

SGS INTERNATIONAL CERTIFICATION SERVICES BERKA, S.A.U.
C/Temporales, 23, 29042 Madrid, España.
T 34 91 313 8115 / 34 91 313 8102 - www.sgs.com

Página 1 de 1

7. CONTROL PANEL

7.1 Equip Characteristics

- “LOGO” is a modular logical controller.
- Electrical box powered with single phase current 230V 50Hz.
- It's equip with a LCD display.
- The operating parameters are configurable. *Consult for other options.

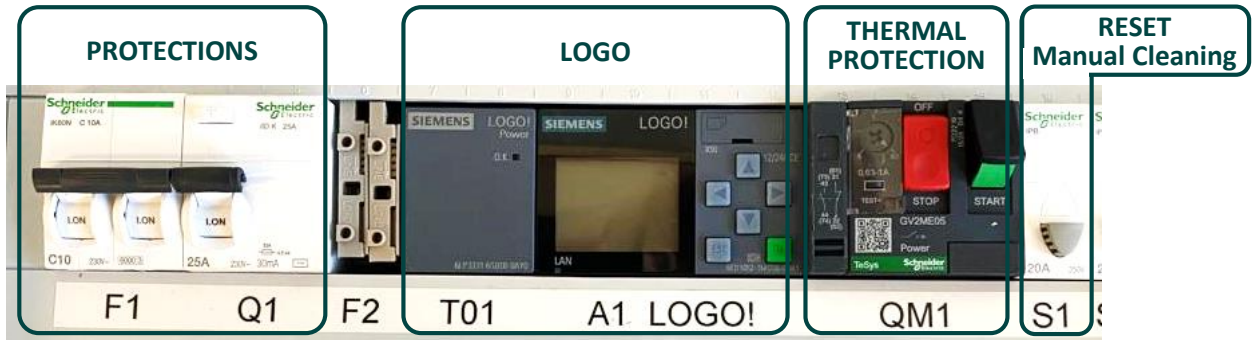

7.2 Program Start

The LOGO controller is equipped with the LCD display, the control panel and the power connections, inputs and outputs.



To enter in the edition mode, the controller has to be started. Pressing any key of the LOGO, it will display the first window where is the main menu (START, PROGRAM, SETUP, NETWORK, DIAGNOSTICS and CARD).

It is showed how to start the operating of the controller below.

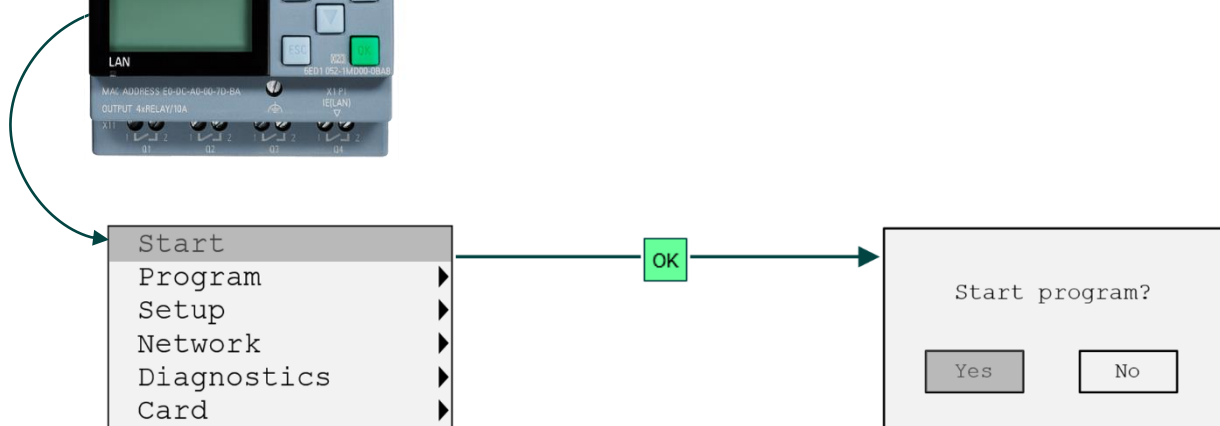

7.3 String of editable fields

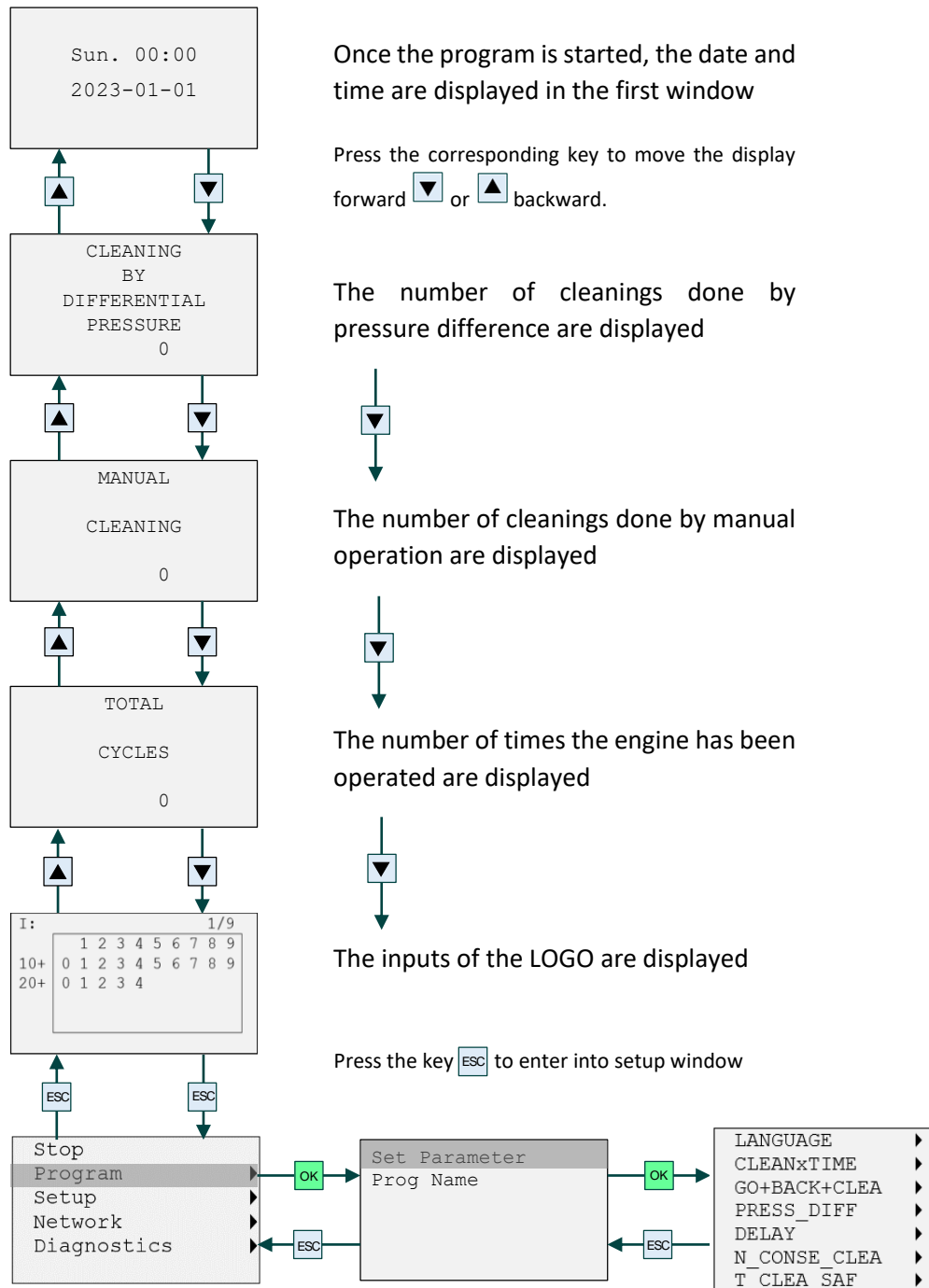

Use the keys ▲, ▼ and **OK** to select "Program". Then, when "Set parameters" is selected, all editable parameters will be displayed.

NOTE: The changed parameters could cause malfunctions or filter failure.

7.3.1. Language (LANGUAGE)

The "LANGUAGE" field allows for changing the language as shown below:

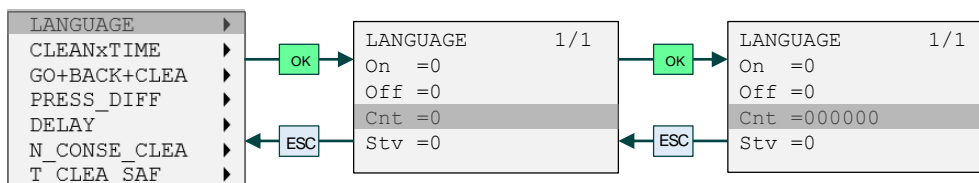

NOTE: Changing the language only affects in the ALARMS fields.

Available languages are classified by the last digit of the number that appears:

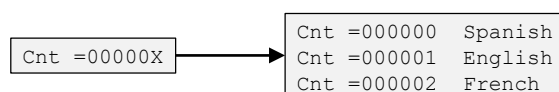

7.3.2. Cleaning time (CLEANxTIME)

The "CLEANxTIME" field indicates the time interval between automatic cleanings, regardless of the pressure difference.

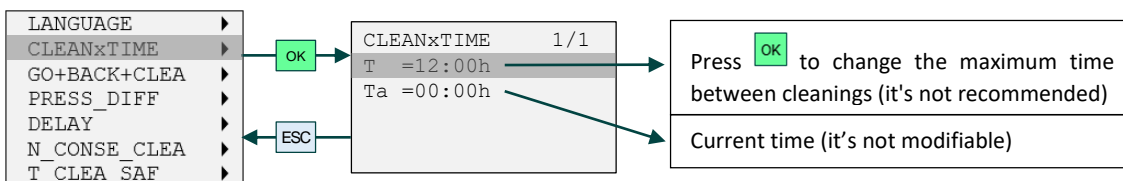

7.3.3. Cleaning mode (GO+BACK+CLEA)

The "GO+BACK+CLEA" field allows for choosing between 2 cleaning modes:

- MODE 1: Switch =On: Perform 2 strokes for cleaning (round trip)
- MODE 2: Switch =Off: Perform 1 strokes for cleaning (go and wait until it receives the next cleaning order).

The steps are shown below:

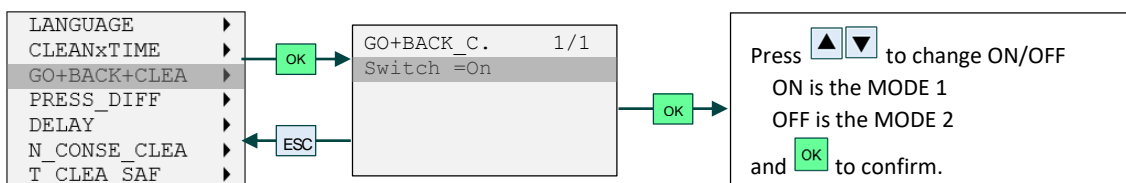

7.3.4. Pressure differential (PRESS_DIFF)

The “PRESS_DIFF” field defines the pressure difference between raw and purified water. This parameter determines when to perform a cleaning by the pressure difference.

The pressure setting can be adjusted by the following steps:

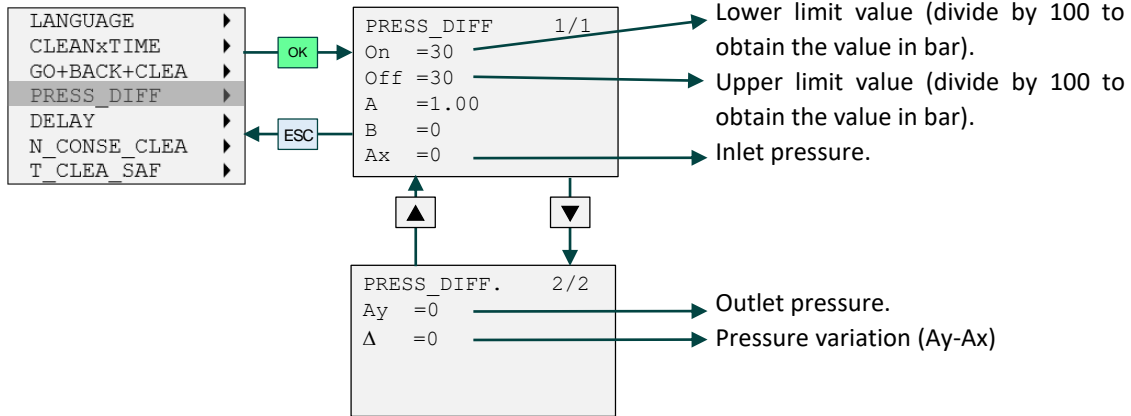

7.3.5. Pressure difference detection time (DELAY)

The “DELAY” field is a safety parameter to absorb turbulence caused by the pressure readings from transducers.

This is the continuous time (seconds) that the pressure difference read by the transducers is above the pressure difference defined in the “PRESS_DIFF” field.

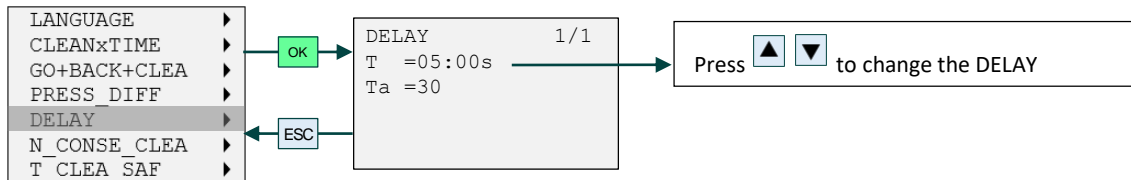

7.3.6. Number of consecutive cleanings (N_CONSE_CLEA)

The “N_CONSE_CLEA” field is a safety parameter to warn that the equipment is working above its rated performance.

It's a counter that analyses whether the equipment are doing consecutive cleanings. When 20 consecutive cleanings are reached, the alarm “Alarm Consecutive Cleaning” appears and the equipment stops self-cleaning until it is manually reset.

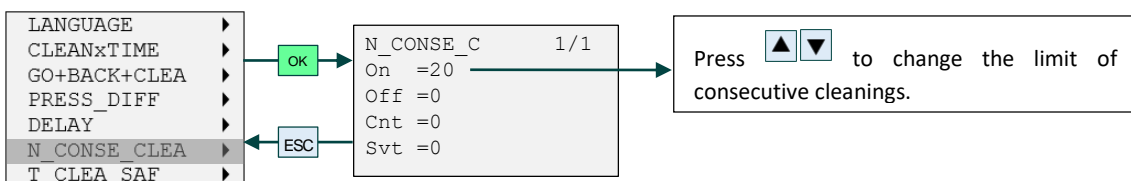

7.3.7. Cleaning safety time (T_CLEA_SAF)

The “T_CLEA_SAF” field is a safety parameter that protects the filter in case the mechanical securities do not work.

It's a timer that starts every time the engine is started. If the engine doesn't complete the stroke in the safety time, the alarm “Alarm Emergency Stop” appears and the equipment stops its self-cleaning until it's manually reset.

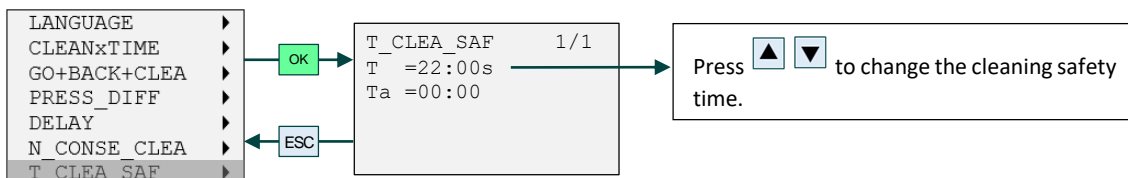

7.3.8. Number of filters in the station (N_OF_FILTER)

The “N_OF_FILTER” field, allow for setting up the number of filters controller by the same programmer.

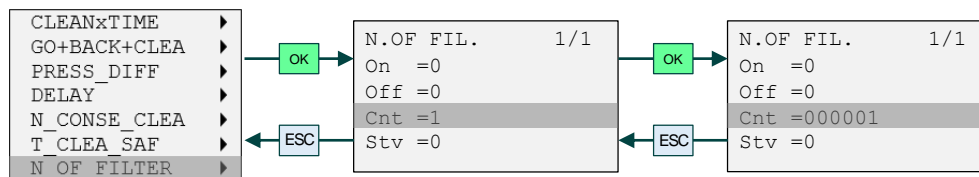

7.4 Alarms

ALARMS	CAUSES	CORRECTIONS
Consecutive Cleaning	The limit of consecutive cleaning have been exceeded (ver 7.3.6.)	Manual reset in the box.
Cleaning Security Time	The spindle has not completed the stroke within the safety time.	Check the spindle position. Manual reset in the box.
Position Sensors	Spindle limit switch failures.	Check spindle limit switch.
Thermal Stop	Engine overload.	Manual reset in the box.
Emergency Stop	Stop button mushroom-head pushed.	Reset the stop button mushroom-head.

7.5 Remote communication

The system is design to remote communication by Ethernet cable.

The filter can be controlled by a PLC Siemens thought the S7 communication protocol via port 102. It also can be controlled by a PLC of other brands thought the Modbus communication protocol via ports 502-510.

The filter IP address is: 192.168.0.3. The IP address is editable from the logo settings. For this the programme must be stopped.

If the programme is active, the display shows the editable fields (7.3. String of editable fields).

Press the keys until you reach the following screen and continue with the sequence:

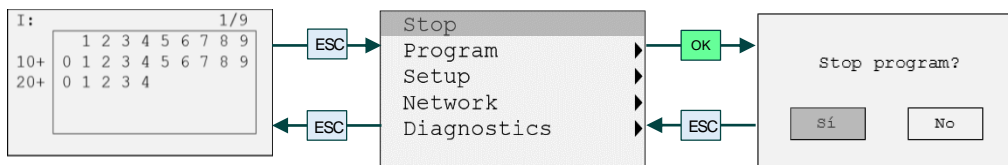

IP address change procedure:

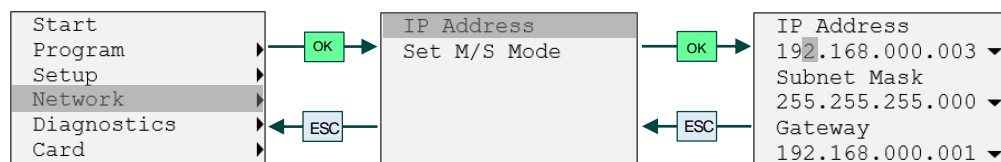

Then press , with keys select a digit and use keys to change this number.

Once the IP address has been changed, reactivate the programme by following the steps in section 7.2. *Program Start*.

Only-read variables are:

NAME	VARIABLE ADDRESS	DESCRIPTION
POSITION_SENSORS	V 30.0	Failure alarm FC spindle
T_CLEA_SAF	V 30.1	Cleaning safety time
N_CONSE_CLEA	V 30.2	Number of consecutive cleanings
EMERGENCY_STOP	V 30.3	Emergency stop alarm
THERMICAL_STOP	V 30.4	Thermal Stop alarm
FILTER_WORKING	V 30.5	Running filter signal
PRESION_INPUT	VW 4	Inlet pressure
PRESION_OUTPUT	VW 8	Outlet pressure
TOTAL_STROKES	VD 0	Number of engine strokes
MANUAL_CLEANINGS	VD 8	Number of manual cleanings
PRESS_DIFF_CLEANING	VD 12	Number of cleanings for pressure differences

Command variables are:

NAME	VARIABLE ADDRESS	LOGO BRAND	DESCRIPTION
REMOTE START	M 1.2	M 11	Manual cleaning start

8. ELECTRICAL DIAGRAM

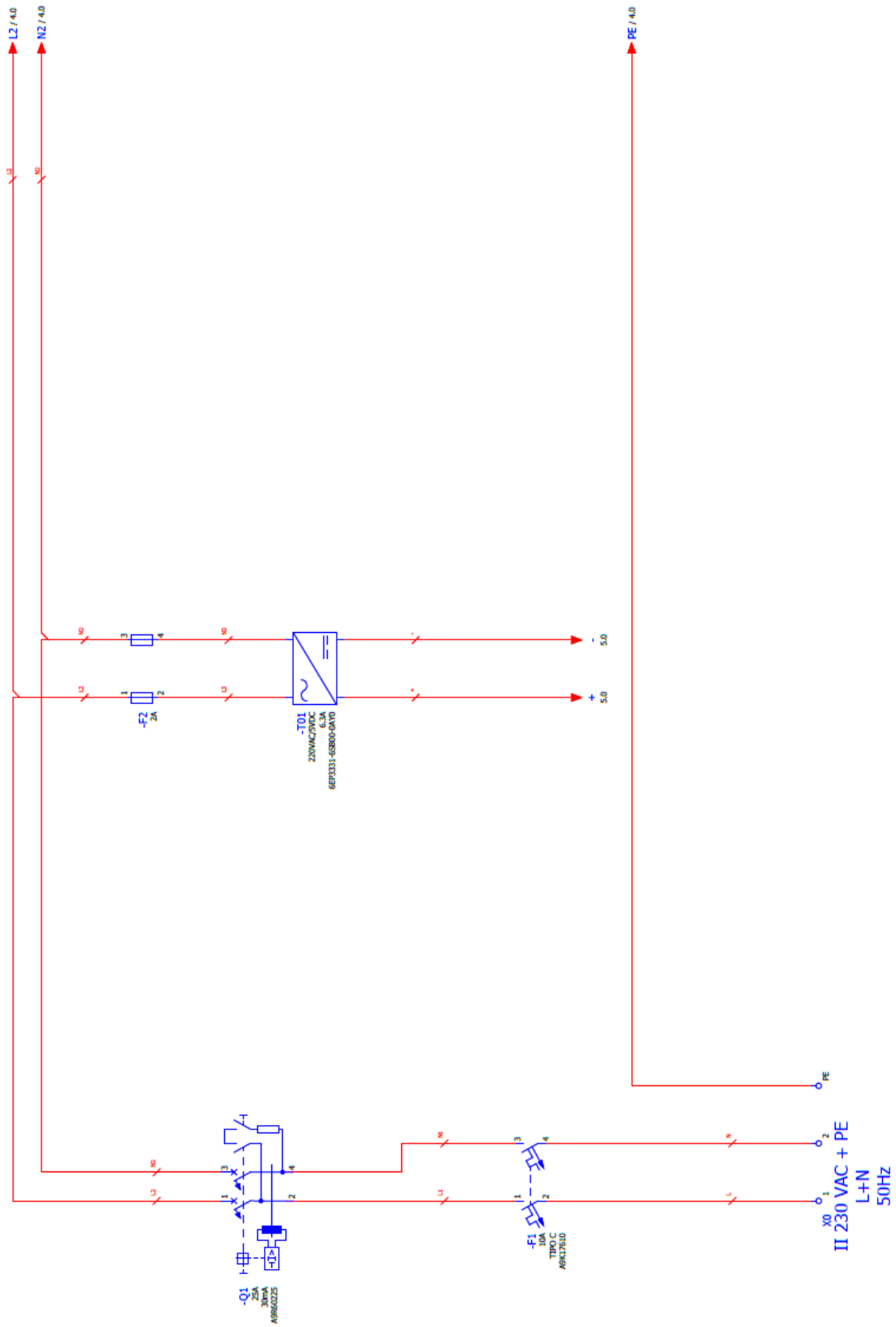

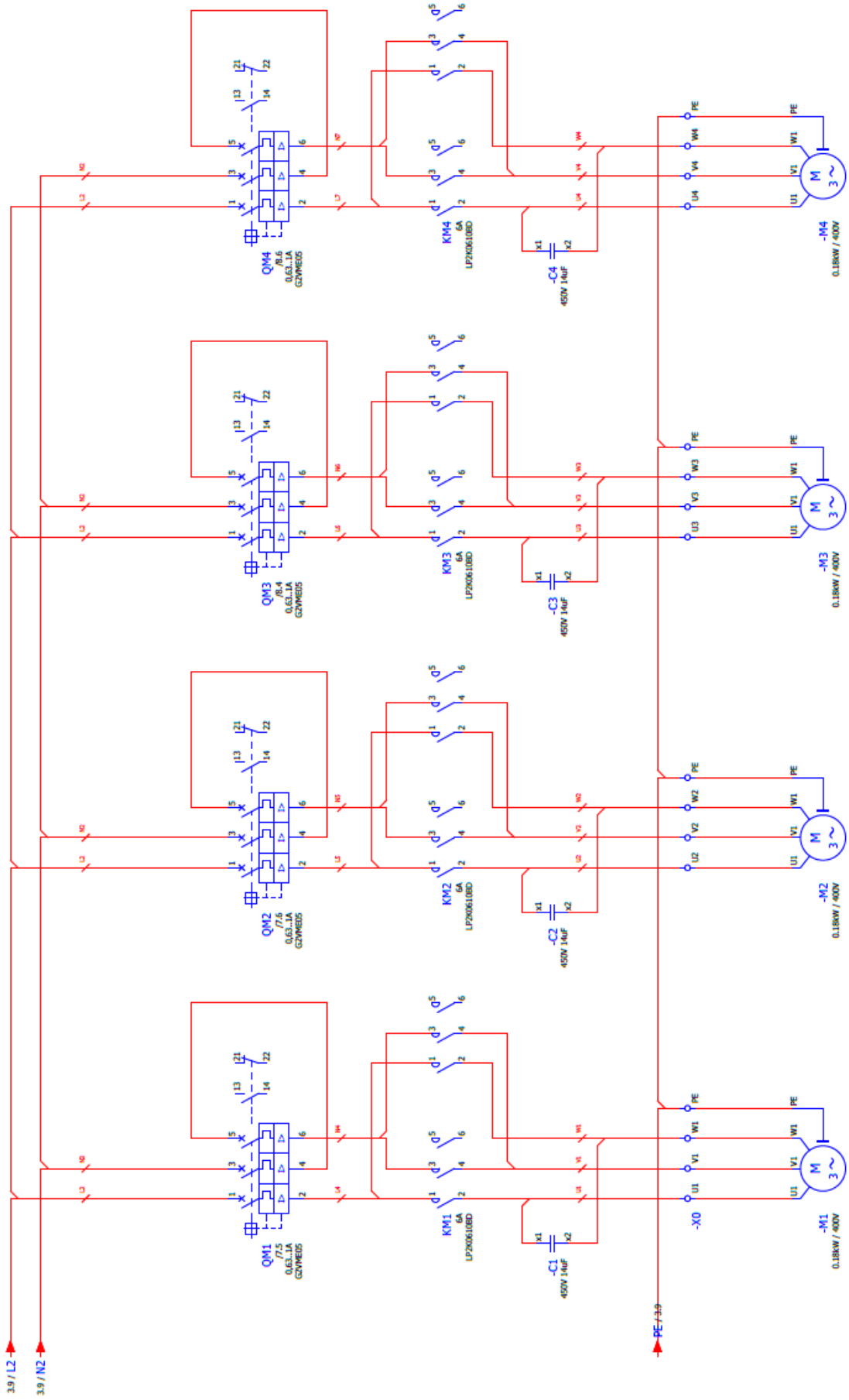

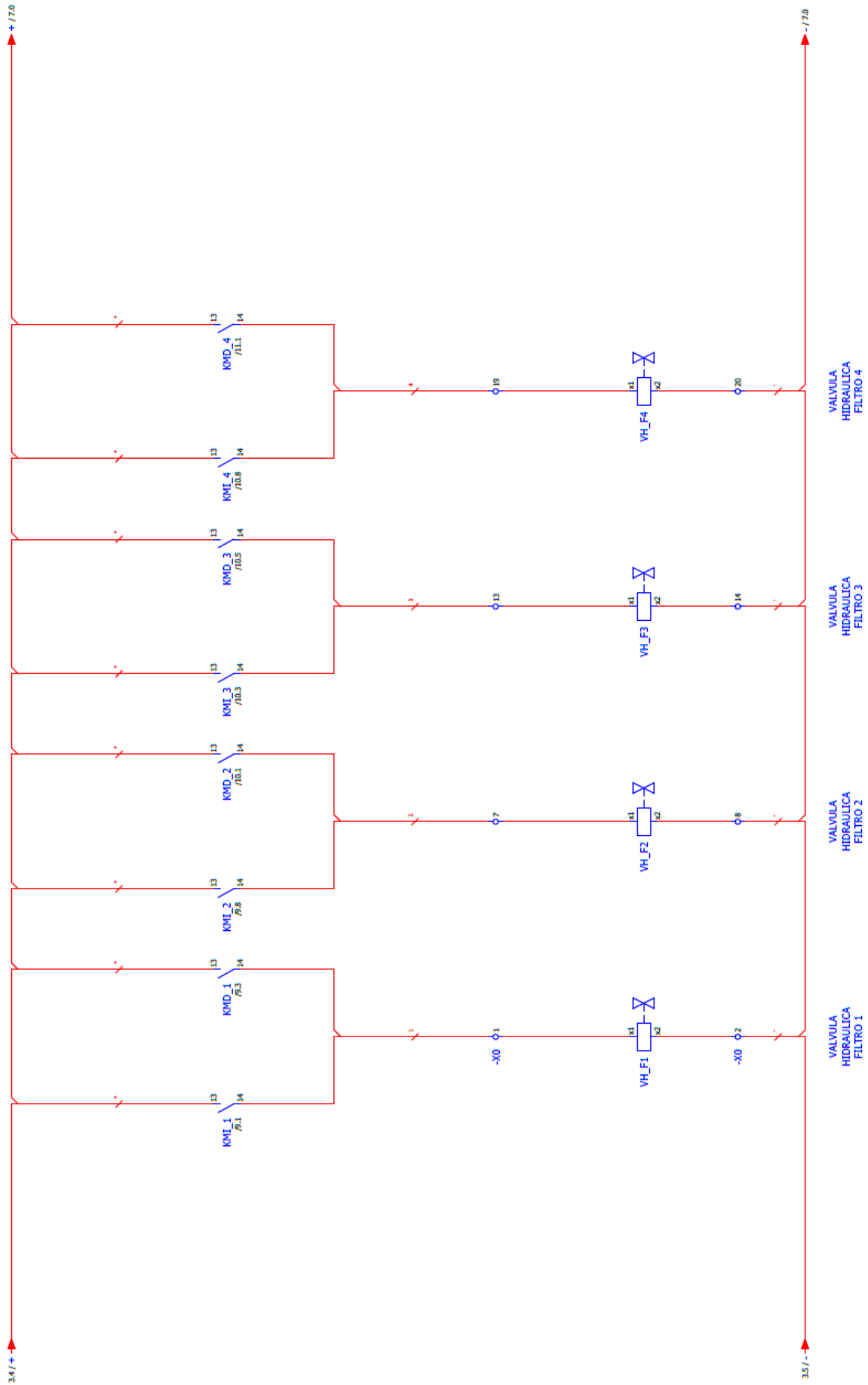

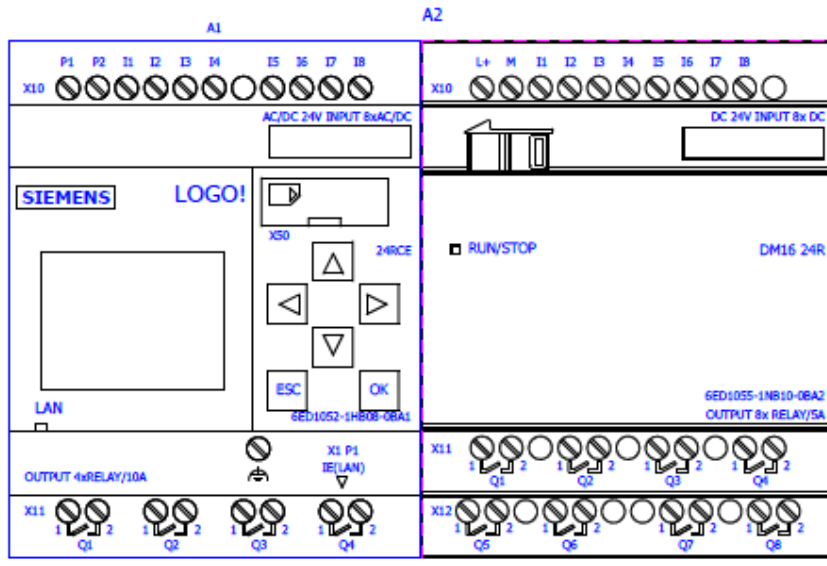

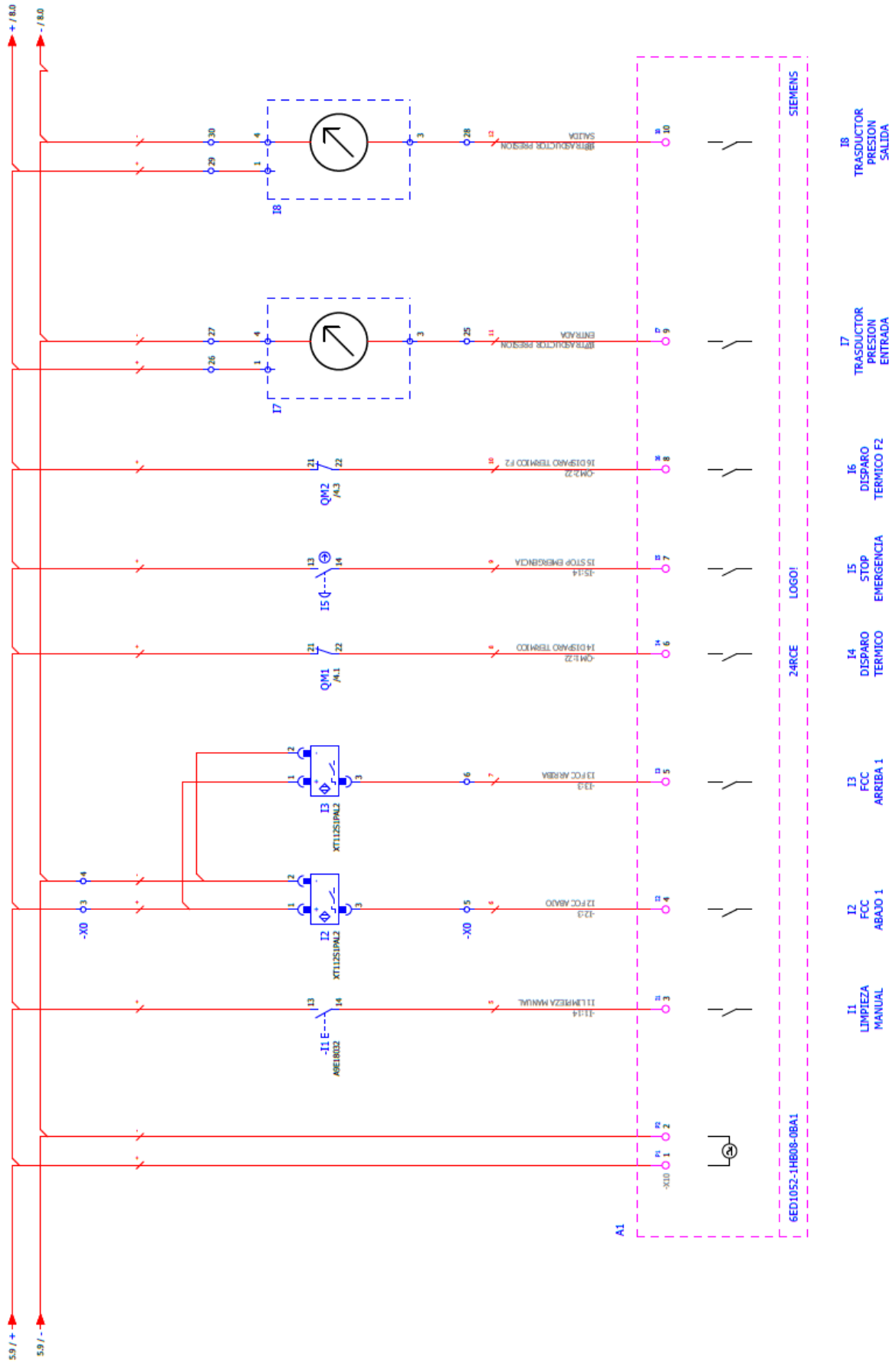

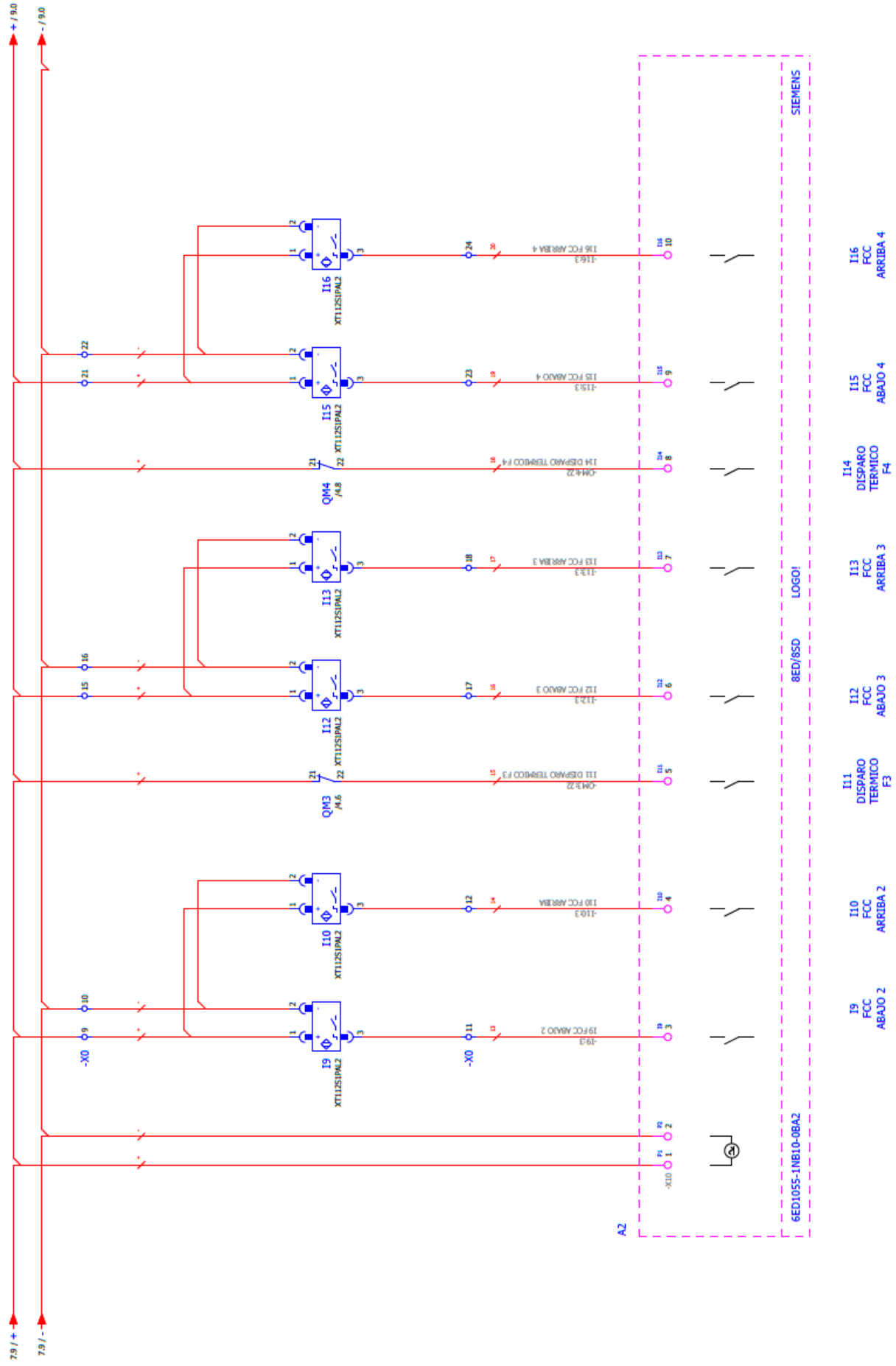

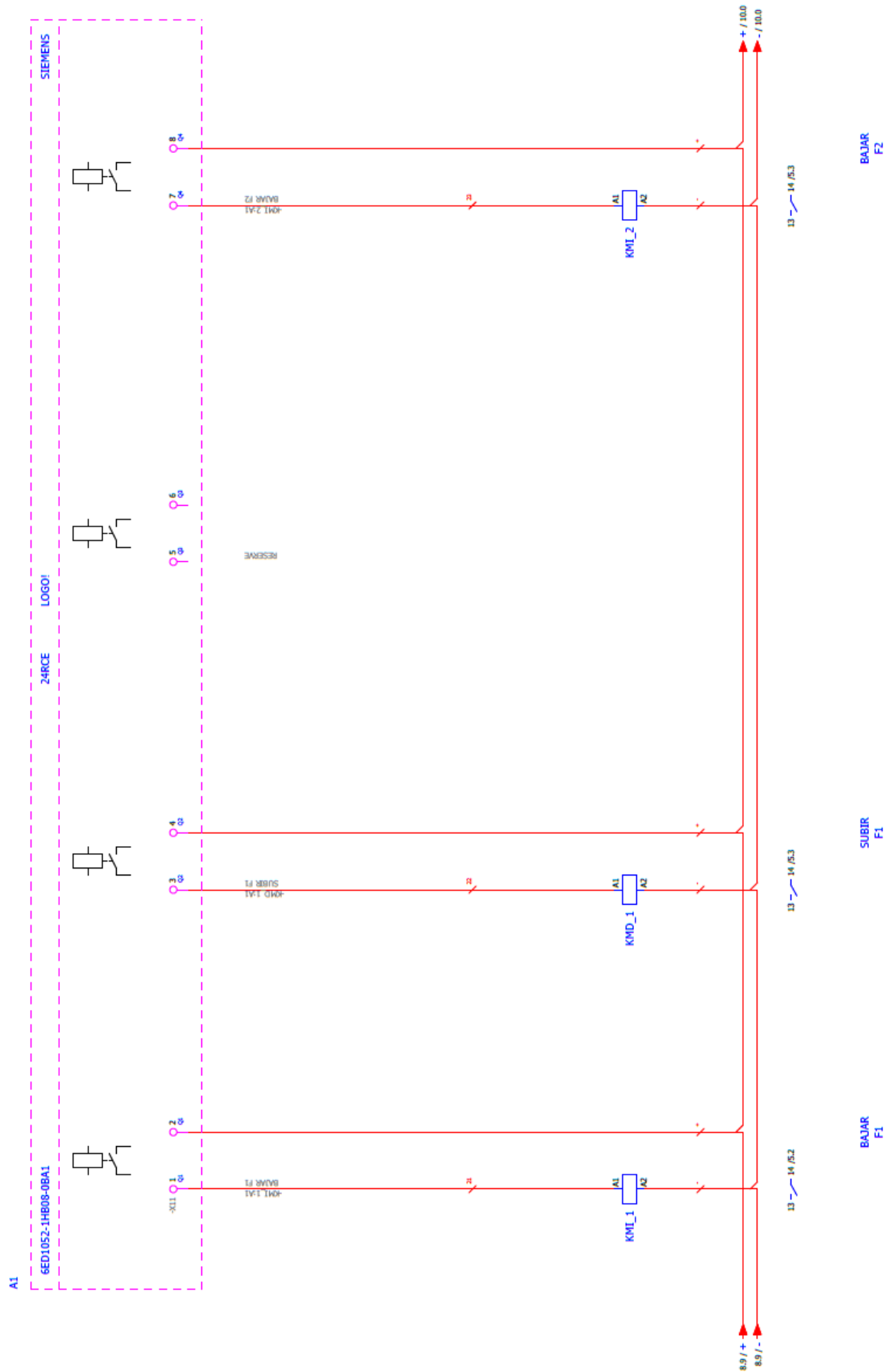

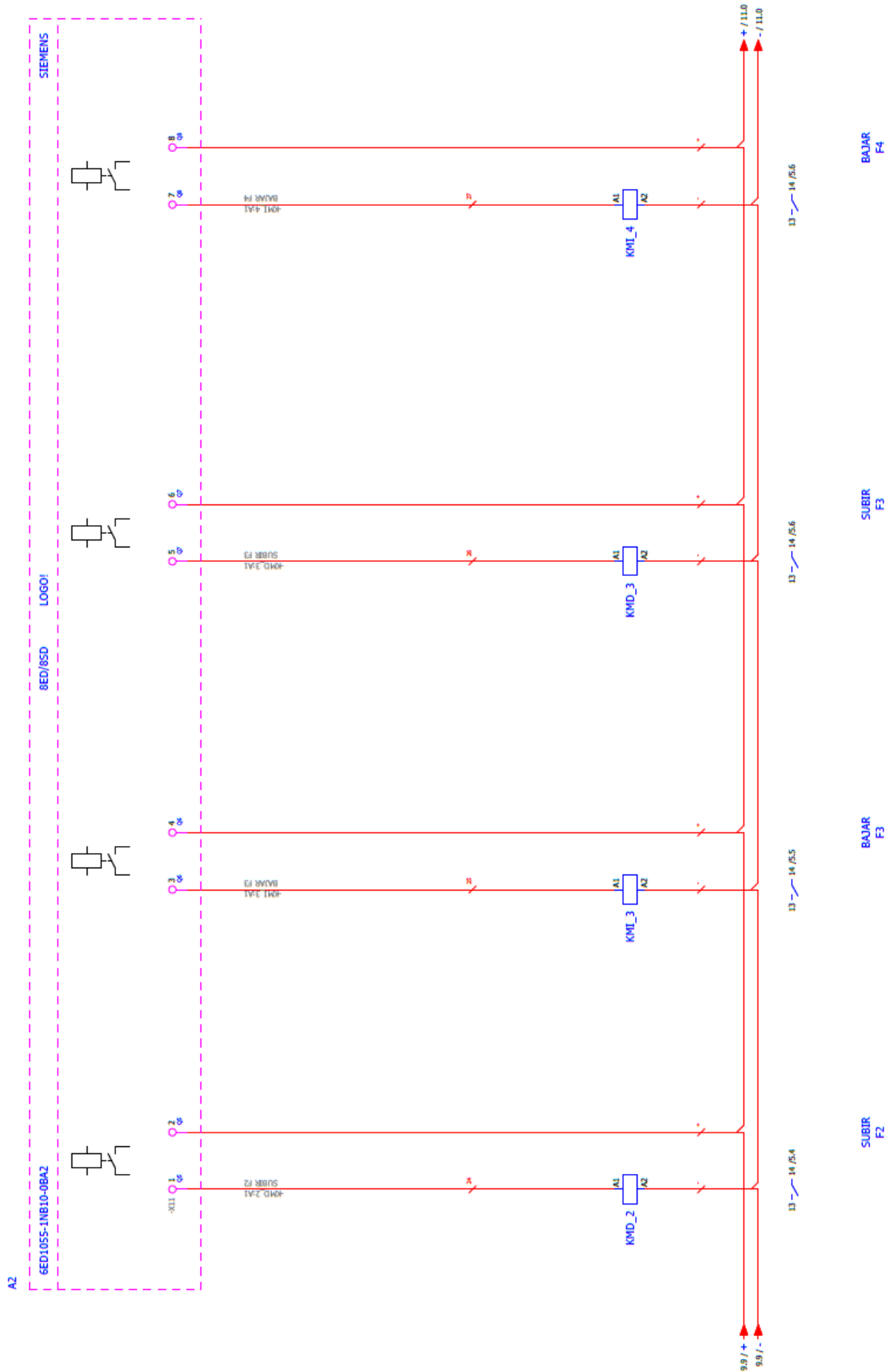

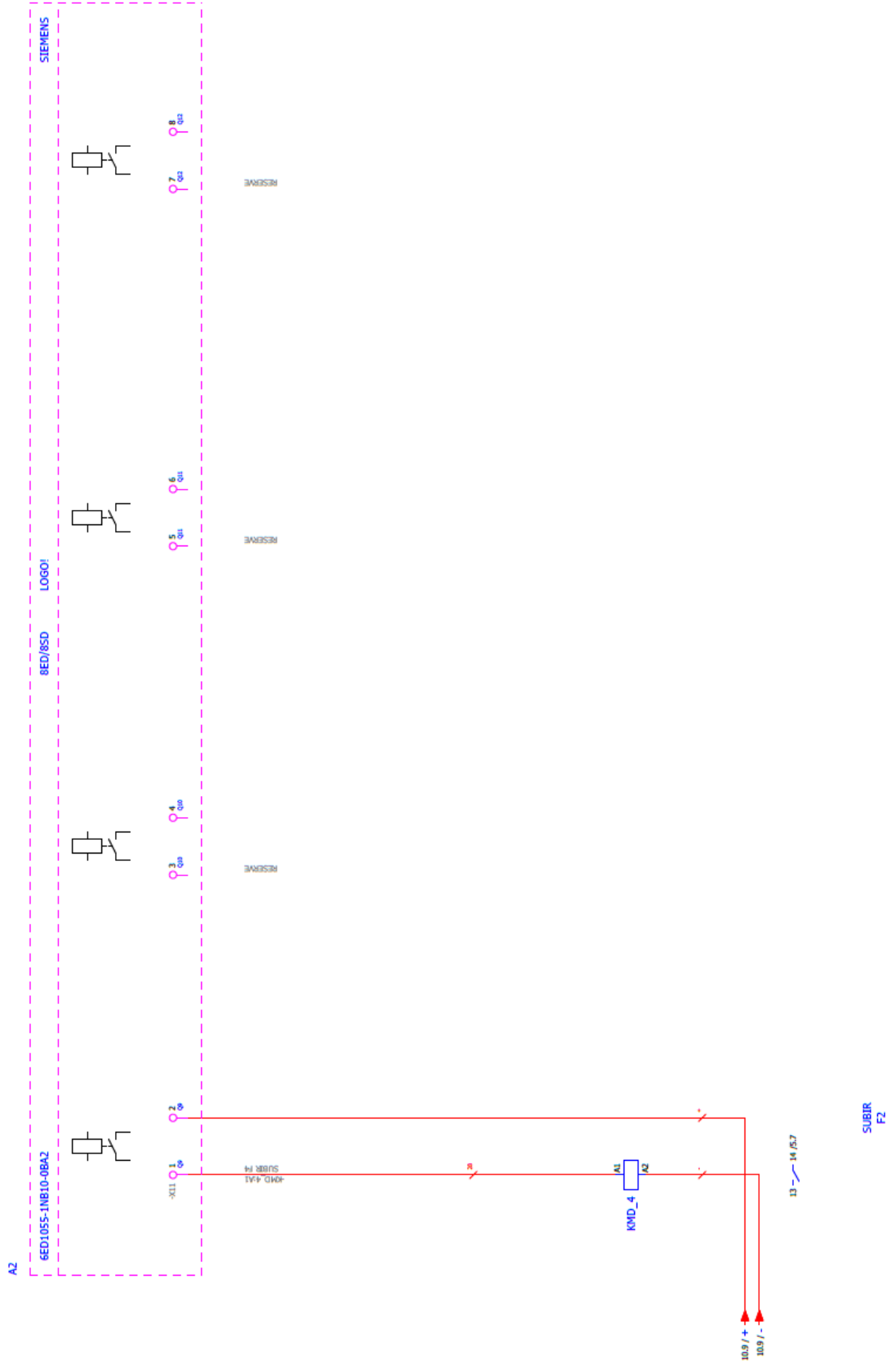

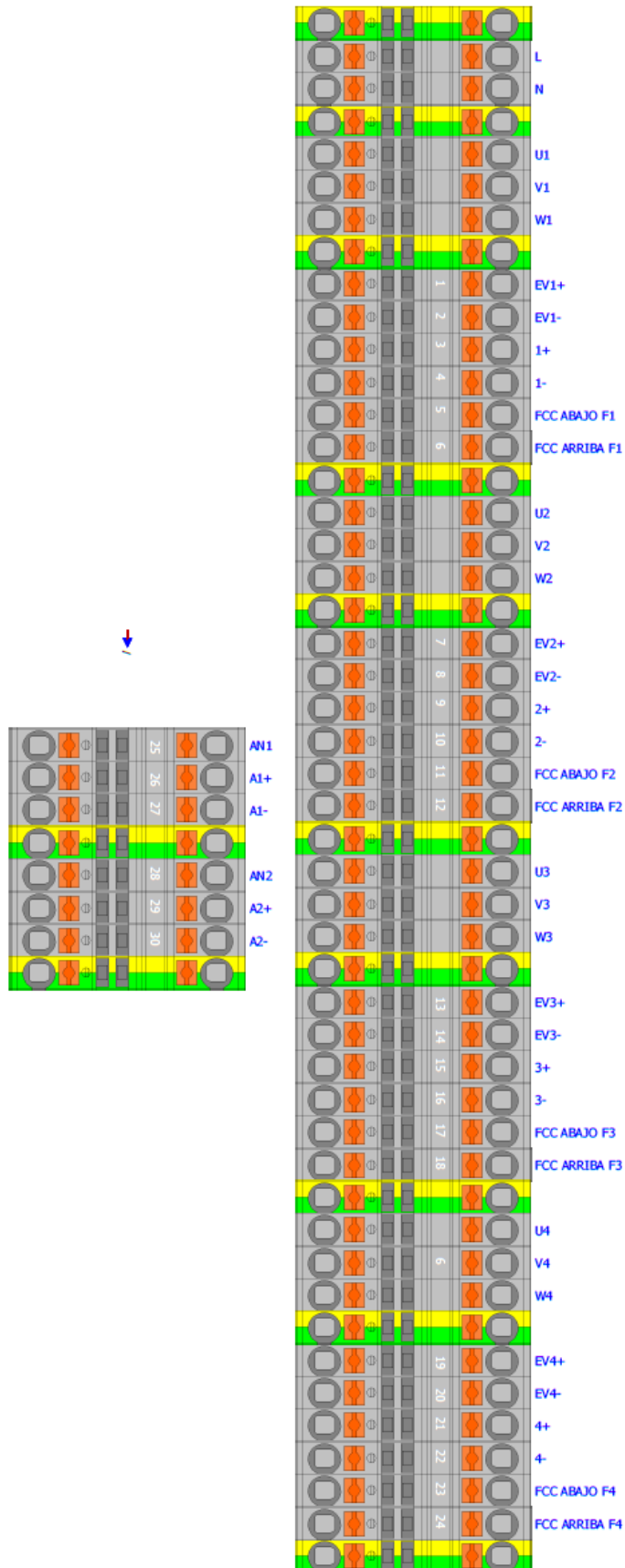

Plano de bornes

Plano_Bornes_itm

Texto de función	Regleta -X0						Nombre de cable	Tipo de cable	Página / columna
	Designación de destino	Borne	Puente	Hilo	Designación de destino	Componente			
	Lugar	Componente			Lugar	Componente			
	F1:2	F1:2	1				/A.1		
	VH_F1x1	VH_F1x1	1		KMI_1:14	KMI_1:14	/B.2		
					KMD_1:14	KMD_1:14	/A.1		
	F1:4	F1:4	2		VH_F1x2	VH_F1x2	/B.2		
	T0:1	T0:1	2		I1:13	I1:13	/A.1		
	I2:1	I2:1	3		QMI:21	QMI:21	/B.2		
					A1:2	A1:2	/A.1		
	I2:2	I2:2	4				/B.2		
							/A.1		
	A1:4	A1:4	5		I2:3	I2:3	/B.2		
	A1:5	A1:5	6		I3:3	I3:3	/A.1		
	VH_F2:1x1	VH_F2:1x1	7		KMI_2:14	KMI_2:14	/B.2		
					KMD_2:14	KMD_2:14	/A.1		
					VH_F2:2	VH_F2:2	/B.2		
	I9:1	I9:1	9		A2:1	A2:1	/A.1		
					QMI:21	QMI:21	/B.2		
	I9:2	I9:2	10		A2:2	A2:2	/A.1		
	A2:3	A2:3	11		I9:3	I9:3	/B.2		
	A2:4	A2:4	12		I10:3	I10:3	/A.1		
	VH_F3:1x1	VH_F3:1x1	13		KMI_3:14	KMI_3:14	/B.2		
					KMD_3:14	KMD_3:14	/A.1		
					VH_F3:2	VH_F3:2	/B.2		
	I12:1	I12:1	15		QMI:21	QMI:21	/A.1		
					QMI:21	QMI:21	/B.2		
	I12:2	I12:2	16				/A.1		
	A2:6	A2:6	17		I12:3	I12:3	/B.2		
	A2:7	A2:7	18		I13:3	I13:3	/A.1		
	VH_F4:1x1	VH_F4:1x1	19		KMI_4:14	KMI_4:14	/B.2		
					KMD_4:14	KMD_4:14	/A.1		
	A1:2	A1:2	20		VH_F4:2	VH_F4:2	/B.2		
	I15:1	I15:1	21		QMI:21	QMI:21	/A.1		
					A1:2	A1:2	/B.2		
	I15:2	I15:2	22				/A.1		
	A2:9	A2:9	23		I15:3	I15:3	/B.2		
	A2:10	A2:10	24		I16:3	I16:3	/A.1		

9. PRODUCT WARRANTY

1. All ITM FILTERS products are guaranteed for 1 year from the date of invoice.
2. The replacement of defective parts is covered by the warranty, being necessary to indicate the serial number and allow the verification by our staff.
3. Take into account the user manual for the installation of the product and check the operating parameters in the technical tables.
4. To obtain a correct filtration, the size of the filter element must be smaller than that of the substances suspended in the water to be filtered.
5. This warranty will not apply in the event of damage or defects produced in the product as a result of or related to:
 - i. Tearing, elimination or manipulation of the identifying label of the product.
 - ii. Improper or unauthorized use of the product by the buyer.
 - iii. An improper assembly or installation that does not correspond to that established by ITM FILTERS.
 - iv. The pertinent periodic cleanings.
 - v. The use of water that does not meet the established quality or is outside the specifications indicated in the technical tables.
 - vi. A use of flow discordant with the water quality according to the parameters defined in the technical tables.
 - vii. Pressures that differ from the established working pressure.
 - viii. The wear of materials caused by fatigue, abrasion or high temperatures.
 - ix. Moisture in electrical components.
 - x. Electrical voltages that differ from those established in the electrical panel.
 - xi. Any external alteration, modification or repair of the products, except by ITM FILTERS and its technical representatives.
 - xii. Damages produced during the transport of the product.
 - xiii. Third party damage, theft or vandalism.
6. At ITM FILTERS we are committed to quality, which is why we have the ISO 9001, ISO 14001 and ISO 45001 certifications. In addition, during the manufacture of our filters we have established our own quality control in which we ensure that the product meets all quality requirements optimally. If you notice any defects, please contact your dealer.
7. For any claim, it is essential to present this document, the serial code of the corresponding product and the purchase invoice.



Water Solutions



INTRAMESA MZ S.A.



Polígono Armentera P-99

22400 Monzón (Huesca)

www.itmfilters.com

info@itmfilters.com

Tel. 974 10 50 05