



DATA SHEET

SELF-CLEANING MESH FILTER
ELECTRIC-300-V-INOX



www.itmfilters.com

1. Data sheet

Working pressure
min. 2 kg/cm²
máx. 10 kg/cm²



IMAGE 1

MODEL	Ø1/Ø0	Flow (m3/h)				Filtration Surface (cm ²)	Water Consumption per Wash (l)	Net Weight (kg)
		Máx. Flow	< 50ppm	50/100 ppm	100/200 ppm			
ELECTRIC-302-V-INOX	Flange 2"	53	26	19	11	1922	6	48
ELECTRIC-303-V-INOX	Flange 3"	92	53	32	22	1922	11,5	58
ELECTRIC-304-V-INOX-COMPACT	Flange 4"	133	65	45	25	1922	11,5	60
ELECTRIC-304-V-INOX	Flange 4"	155	73	53	27	2804	13,5	73
ELECTRIC-306-V-INOX-COMPACT	Flange 6"	195	86	65	42	2804	14	75
ELECTRIC-306-V-INOX	Flange 6"	285	93	73	52	5608	28	97

TABLE 1

1.1. Manufacturing technical characteristics:

- Materials:
 - Stainless steel metal components.
 - A2 stainless steel screws.
 - Mesh cartridge : Injected plastic structure with AISI-316 Stainless Steel. Filtration degree: 125 microns.
 - Grinding cartridge: AISI-304 Stainless Steel.
 - EPDM gaskets: 60 SHORE.
- Superficial treatment:
 - Surface shot blasting up to SA ½ grade.
- Working characteristics:
 - Maximum operating temperature 50°C.
- Commercial components:
 - 1" Suction Cup and 2" Flushing Valve.
 - Electrical box powered with single phase current 230V 50Hz. *Consult other options.

1.2. Dimensions

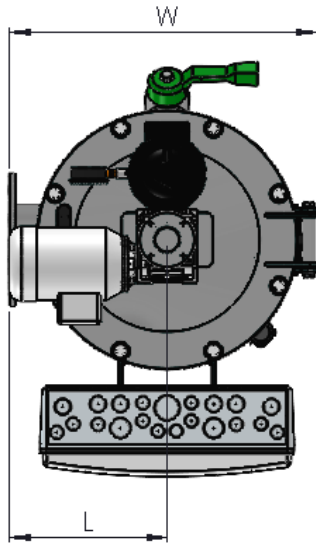
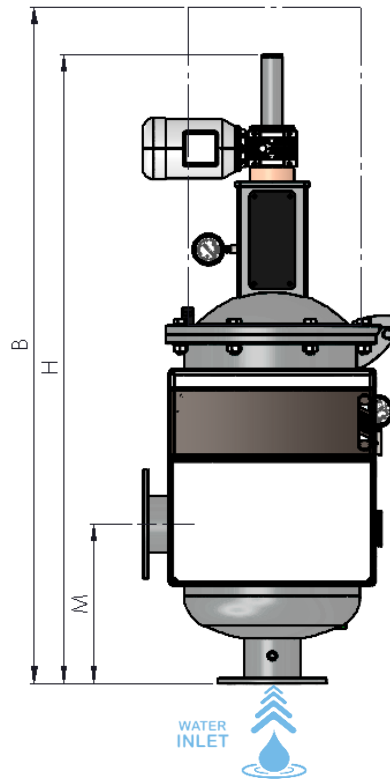

IMAGE 2



MODEL	Dimensions (mm)				
	M	L	H	W	B
ELECTRIC-302-V-INOX	250	220	1350	430	1163
ELECTRIC-303-V-INOX	250	220	1350	430	1163
ELECTRIC-304-V-INOX-COMPACT	250	220	1350	430	1163
ELECTRIC-304-V-INOX	320	260	1290	520	1470
ELECTRIC-306-V-INOX-COMPACT	320	260	1290	520	1470
ELECTRIC-306-V-INOX	470	260	1577	520	1770

TABLE 2

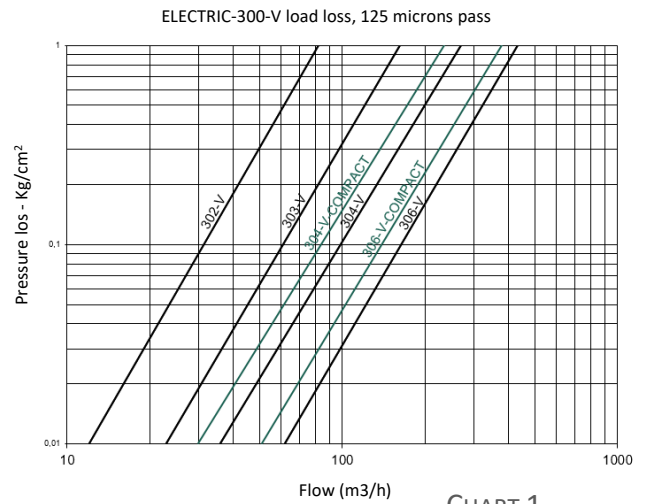

CHART 1

MODEL	General Data					
	Minimum Pressure (Bar)	Nozzle Units	Auto Flushing Valve	Manual Exhaust Valve	Washing Time (s)	Motor Power (kW)
ELECTRIC-302-V-INOX	2	3	1"	1"	25	0,18
ELECTRIC-303-V-INOX	2	3	1-1/2"	1"	25	0,18
ELECTRIC-304-V-INOX-COMPACT	2	3	1-1/2"	1"	25	0,18
ELECTRIC-304-V-INOX	2	2	2"	1-1/2"	25	0,18
ELECTRIC-306-V-INOX-COMPACT	2	2	2"	1-1/2"	25	0,18
ELECTRIC-306-V-INOX	2	4	2"	1-1/2"	25	0,18

TABLE 3

1.3. Hydraulic & Electric circuit – ELECTRIC-300-V-INOX

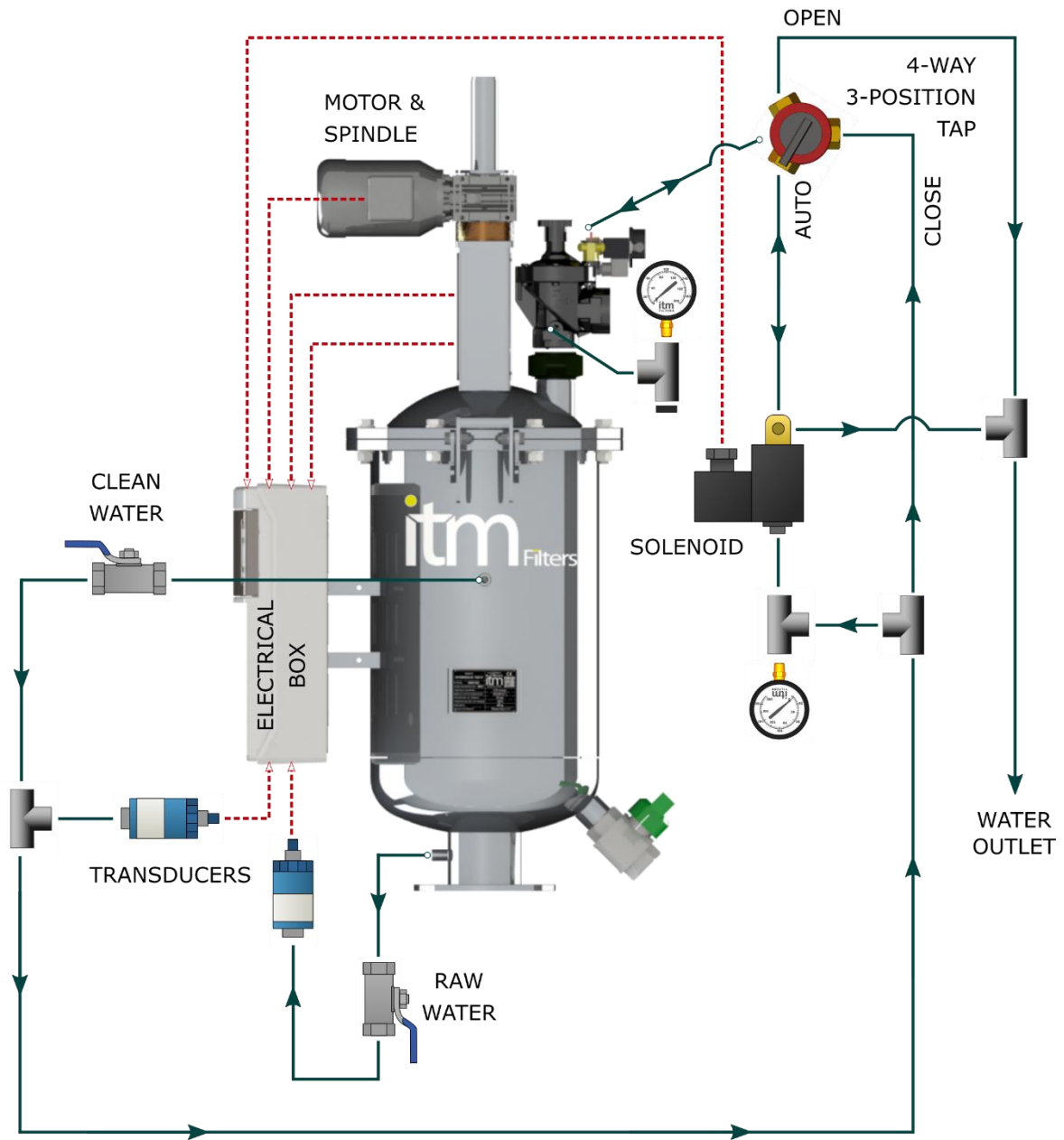

IMAGE 3

* Dashed lines represent an electrical signal: -----
 Continuous lines represent a hydraulic signal: —————

- * The 4-way tap has 3 positions:
- *AUTO* : filter operation with automatic cleaning.
 - *OPEN* : cleaning cycle.
 - *CLOSE* : filter operation (without automatic cleaning)



Filters
itm
Water Solutions



INTRAMESA MZ S.A.

**Polígono Armentera P-99
22400 Monzón (Huesca)**

www.itmfilters.com

info@itmfilters.com

Tel. 974 10 50 05