



USER MANUAL

SAND FILTERS

ARM SAND FILTER (FBR)

Serial number: _____

Purchase date: _____



www.itmfilters.com

INDEX

1.	Introduction	1
1.1	Filter identification	1
1.2	Basic concepts	1
2.	Data Sheet.....	2
2.1	Arm Sand Filter (FBR).....	2
2.2	Dimensions FBR	3
3.	Installation	4
4.	Operation	4
5.	Maintenance and spare parts.....	4
5.1	Maintenance	4
5.2	Exploded view	5
6.	Product warranty	6

1. INTRODUCTION

First of all, we want to thank you for purchasing this filter, the result of the work of a group of people committed to offering the correct solution to each filtration process. All products designed and manufactured by ITM Filters meet self-imposed requirements for quality, efficiency and durability. This philosophy is accredited through certification by external bodies.

The highest efficiency of the system is obtained with correct operation and maintenance, please properly follow the indications in this manual throughout the life of the product. We invite you to visit our website: www.itmfilters.com for more information about our products and our company policies.

1.1 Filter identification

The filter is identified with the following decal:



IMAGE 1

1.2 Basic concepts

Filtration surface: Area that allows water to pass while retaining suspended particles.

Recommended flow: Optimal filtration must take into account the quality of the source water and its use. The quality of the source water is divided into 4 sections, which have maximum theoretical flows. The sectorization corresponds to the particles per million diluted in the water.

- Stretch 1: 0-50 ppm.
- Stretch 2: 50-100 ppm.
- Stretch 3: 100/200 ppm.
- Stretch 4: >200 ppm.

Loss of pressure: It is the difference in load produced between two points of the same flow. The friction of the water with the filter medium produces a loss of energy. The diluted substances are trapped in the mesh generating a decrease in the porosity of the filter medium, which causes an increase in the pressure drop. The pressure drop measurement is carried out by means of a pressure tap on the inlet manifold and another one on the outlet manifold.

2. DATA SHEET

2.1 Arm Sand Filter (FBR)



Working pressure
máx. 8 kg/cm²

IMAGE 2

MODEL	ØI	ØO	Flows (m ³ /h)				Filtration Surface (cm ²)	Net Weight (kg)	Sand (kg)
			Qmax	< 50ppm	50/100ppm	100/200ppm			
FBR-500 (1-½" - H/H)	Female Thread 1-½"	Female Thread 1-½"	16	8	5	3,5	1963	43	100
FBR-600 (1-1/2" - H/H)	Female Thread 1-½"	Female Thread 1-½"	19	10	6	4	2827	57	150
FBR-700 (2" - V/H)	Victaulic 2"	Female Thread 2"	26	13	8	5,5	3848	61	225
FBR-800 (2" - V/H)	Victaulic 2"	Female Thread 2"	33	18	11	7	5027	83	325
FBR-900 (3" - V/B)	Victaulic 3"	Flange 3"	42	23	14	9	6362	112	425
FBR-950 (3" - V/B)	Victaulic 3"	Flange 3"	46	26	16	11	7088	126	500
FBR-1200 (4" - V/B)	Victaulic 4"	Flange 4"	76	36	20	15	11310	176	800

TABLE 1

Manufacturing technical characteristics:

- Materials:
 - Carbon steel metal components.
 - Zinc plated screws 6.8.
 - EPDM gaskets: 60 SHORE.
- Superficial treatment:
 - Surface shot blasting up to SA ½ grade.
 - Two-layer EPOXY-POLYESTER powder paint finish, oven-polymerized RAL 6004.
- Working characteristics:
 - Maximum operating temperature 50°C.

2.2. Dimensions FBR

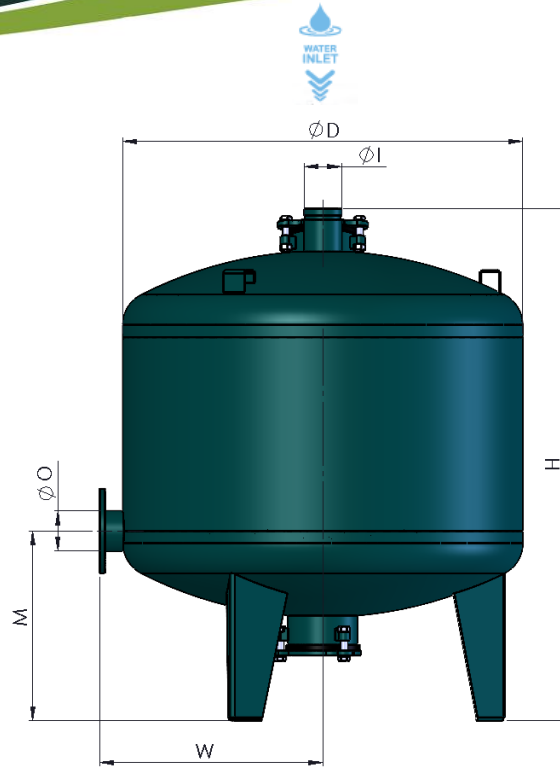

IMAGE 3

MODEL	Dimensions (mm)			
	ØD	H	M	W
FBR-500 (1-½" - H/H)	500	900	350	286
FBR-600 (1-½" - H/H)	600	900	350	380
FBR-700 (2" - V/H)	700	940	350	396
FBR-800 (2" - V/H)	800	1100	450	480
FBR-900 (3" - V/B)	900	1215	450	510
FBR-950 (3" - V/B)	950	1215	450	530
FBR-1200 (4" - V/B)	1200	1215	450	665

TABLE 2
FBR load loss

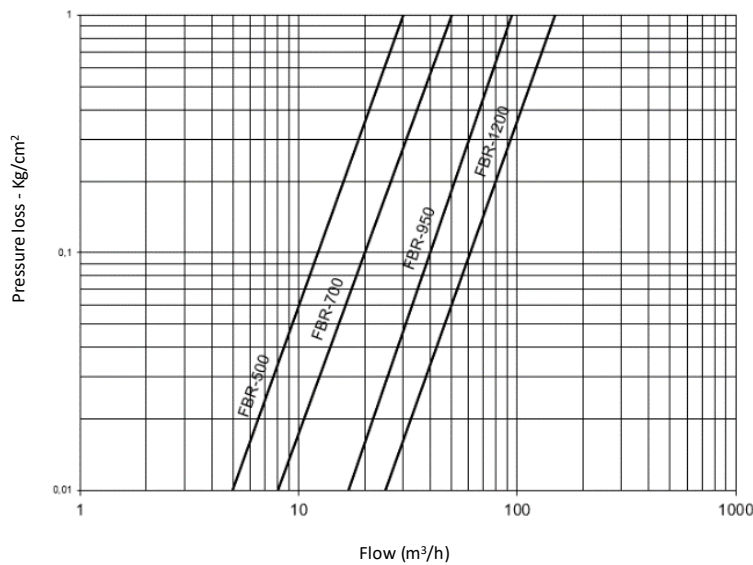

CHART 1

3. INSTALLATION

1. Place the filter on a flat surface. If more than one filter is purchased and they are stacked, they must be separated by unscrewing the union on the upper supports.
2. Position the inlet and outlet manifolds, fixing the flanges with their corresponding gaskets.
3. Connect the drainpipes and direct to the desired area.
4. Filter filling. First fill the water filter halfway. Open the top cover and pour the filter material slowly to avoid damage to the internal structure. The amount of sand required is indicated in the technical sheet (Page 2).
5. Place the pressure gauges, one on the water inlet manifold and the other on the filtered water outlet manifold.
6. Check that the unions are tight, turn on the water supply and verify that there is no leak.
7. Carry out a first cleaning to remove possible impurities from the sand.
8. Filtering. Open the water flow at the recommended flow rate (depending on the quality of the water) and at a working pressure of 8 kg/cm².
9. When the pressure gauges indicate a pressure difference equal to or greater than 0.5 kg/cm², clean the filter by reversing the direction of the water.

4. OPERATION

Sand filtration is a highly efficient and in-depth filtration method. It consists in the physical separation between water and the substances that are suspended in it. The water descends through the filter bed of sand where impurities are trapped, and the system of arms allows the filtered water to escape.

When the sand filter becomes clogged, it produces a pressure difference between the water inlet and outlet. The cleaning cycle begins when a pressure difference of 0.5 kg/cm is reached. The cleaning cycle consists in reversing the direction of circulation: the water rises and carries all the particles trapped in the sand filter bed and it is expelled.

5. MAINTENANCE AND SPARE PARTS

5.1 Maintenance

1. Avoid leaving the filter without water for proper maintenance of the filter material. If the sand becomes dry and caked, open the lower mouth of the filter, empty its contents and replace it. In case the sand does not evacuate properly, connect the water flow to facilitate its exit.
2. Proper filter maintenance includes checking the condition of the paint. Damage caused by corrosion must be corrected.

5.2 Exploded view

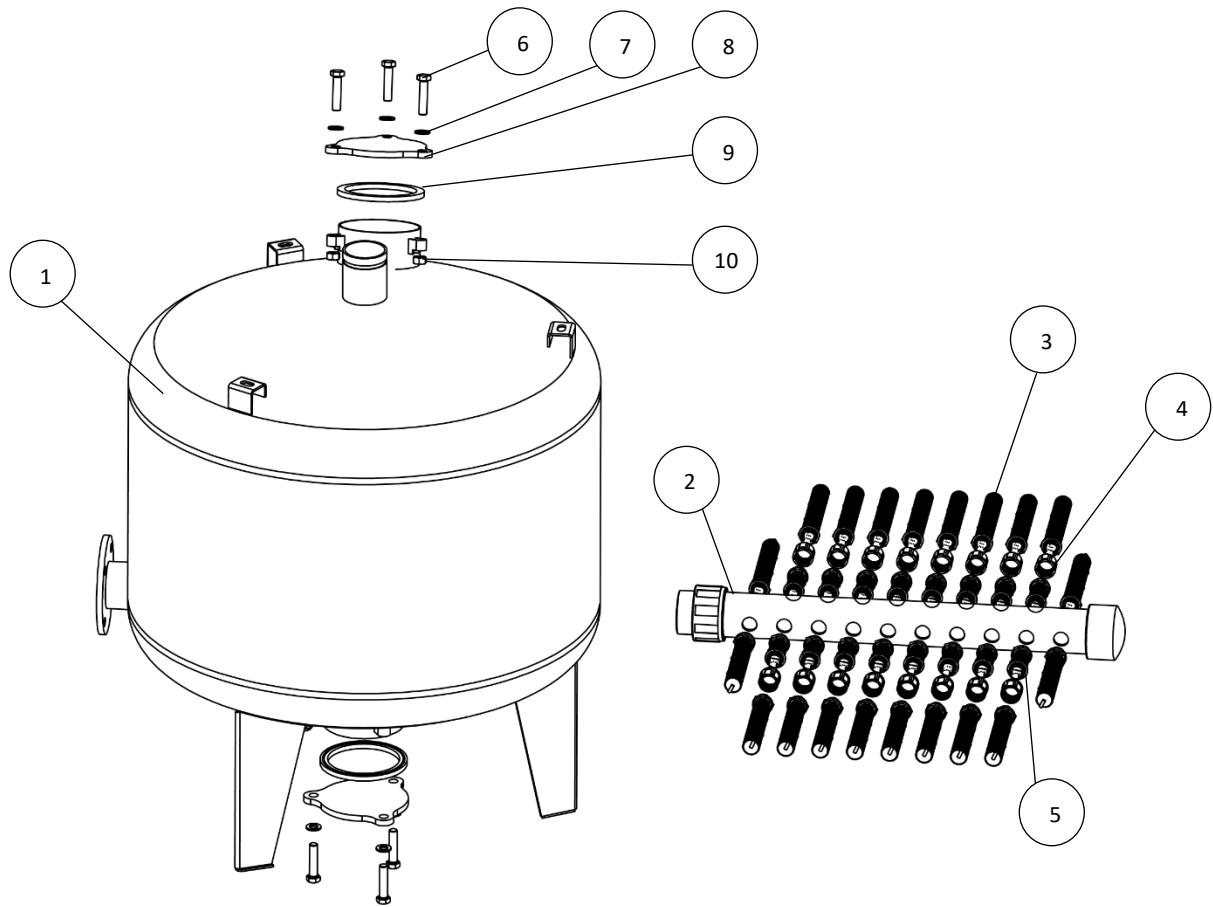

Nº	DENOMINATION	FBR MODELS							
		FBR-500		FBR-700		FBR-950		FBR-1200	
		U.	Code	U.	Code	U.	Code	U.	Code
1	Body	1	FBR-500-02	1	FBR-700-02	1	FBR-950-02	1	FBR-1200-02
2	Arm holder pipe	1	FBR-500-03-00	1	FBR-700-03-00	1	FBR-950-03-00	1	FBR-1200-03-00
3	Collector arm 1" L=110	4	Ref. 06437	-	-	-	-	-	-
	Collector arm 1" L=160	6	Ref. 06436	4	Ref. 06436	-	-	4	Ref. 06436
4	Collector arm 1" L=225	-	-	8	Ref. 06435	20	Ref. 06435	22	Ref. 06435
	Cuff link 1"	-	-	-	-	16	Ref. 06439	40	Ref. 06439
5	Arm extension 1" L=100	-	-	-	-	16	Ref. 06438	40	Ref. 06438
6	Hex screw M16	6	DIN933	6	DIN933	6	DIN933	9	DIN933
7	Flat washer D16	6	DIN125	6	DIN125	6	DIN125	9	DIN125
8	Loading manhole cover	2	FBR-500-05	2	FBR-500-05	2	FBR-500-05	3	FBR-500-05
9	Gasket	2	FBR-500-09	2	FBR-500-09	2	FBR-500-09	3	FBR-500-09
10	Hex nut M16	6	DIN934	6	DIN934	6	DIN934	9	DIN934

TABLE 3

6. PRODUCT WARRANTY

1. All ITM FILTERS products are guaranteed for 1 year from the date of invoice.
2. The replacement of defective parts is covered by the warranty, being necessary to indicate the serial number and allow the verification by our staff.
3. Take into account the user manual for the installation of the product and check the operating parameters in the technical tables.
4. To obtain a correct filtration, the size of the filter element must be smaller than that of the substances suspended in the water to be filtered.
5. This warranty will not apply in the event of damage or defects produced in the product as a result of or related to:
 - i. Tearing, elimination or manipulation of the identifying label of the product.
 - ii. Improper or unauthorized use of the product by the buyer.
 - iii. An improper assembly or installation that does not correspond to that established by ITM FILTERS.
 - iv. The pertinent periodic cleanings.
 - v. Arm damage caused by the poor maintenance of the sand.
 - vi. The use of water that does not meet the established quality or is outside the specifications indicated in the technical tables.
 - vii. A use of flow discordant with the water quality according to the parameters defined in the technical tables.
 - viii. Pressures that differ from the established working pressure.
 - ix. The wear of materials caused by fatigue, abrasion or high temperatures.
 - x. Any external alteration, modification or repair of the products, except by ITM FILTERS and its technical representatives.
 - xi. Damages produced during the transport of the product.
 - xii. Third party damage, theft or vandalism.
6. At ITM FILTERS we are committed to quality, which is why we have the ISO 9001, ISO 14001 and ISO 45001 certifications. In addition, during the manufacture of our filters we have established our own quality control in which we ensure that the product meets all quality requirements optimally. If you notice any defects, please contact your dealer.
7. For any claim, it is essential to present this document, the serial code of the corresponding product and the purchase invoice.



Water Solutions



INTRAMESA MZ S.A.



Polígono Armentera P-99

22400 Monzón (Huesca)

www.itmfilters.com

info@itmfilters.com

Tel. 974 10 50 05