



USER MANUAL

METALIC MANUAL FILTER FY-CM MANUAL BRUSH CLEANING

Serial number: _____

Purchase date: _____



INDEX

- 1. Introduction 1
 - 1.1 Filter identification 1
 - 1.2 Basic concepts 1
- 2. Data sheet 2
 - 2.1 FY Manual Brush Cleaning (FY-CM) 2
 - 2.2 Manufacturing technical characteristics 3
- 3. Installation 3
- 4. Operation and maintenance 3
- 5. Spare parts 4
 - 5.1 Exploded view FY Manual Brush Cleaning 4
- 6. Product warranty 5

1. INTRODUCTION

First of all, we want to thank you for purchasing this filter, the result of the work of a group of people committed to offering the correct solution to each filtration process. All products designed and manufactured by ITM Filters meet self-imposed requirements for quality, efficiency and durability. This philosophy is accredited through certification by external bodies.

The highest efficiency of the system is obtained with correct operation and maintenance, please properly follow the indications in this manual throughout the life of the product. We invite you to visit our website: www.itmfilters.com for more information about our products and our company policies.

1.1 Filter identification

The filter is identified with the following decal:

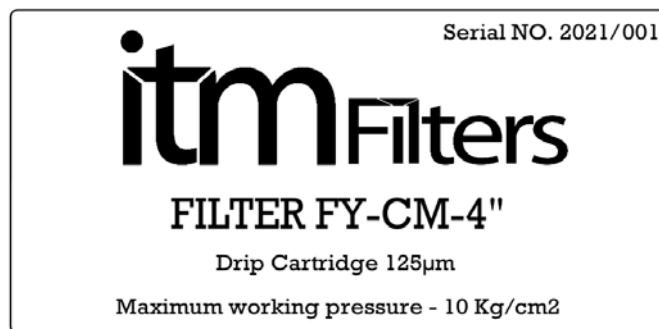

IMAGE 1

1.2 Basic concepts

Filtration surface: Area that allows water to pass while retaining suspended particles.

Loss of pressure (HEAD LOSS): It is the difference in load produced between two points of the same flow. The friction of the water with the filter medium produces a loss of energy. The diluted substances are trapped in the mesh generating a decrease in the porosity of the filter medium, which causes an increase in the pressure drop.

The pressure drop measurement is carried out by means of a pressure tap on the inlet manifold and another one on the outlet manifold.

2. DATA SHEET

2.1 FY Manual Brush Cleaning (FY-CM)

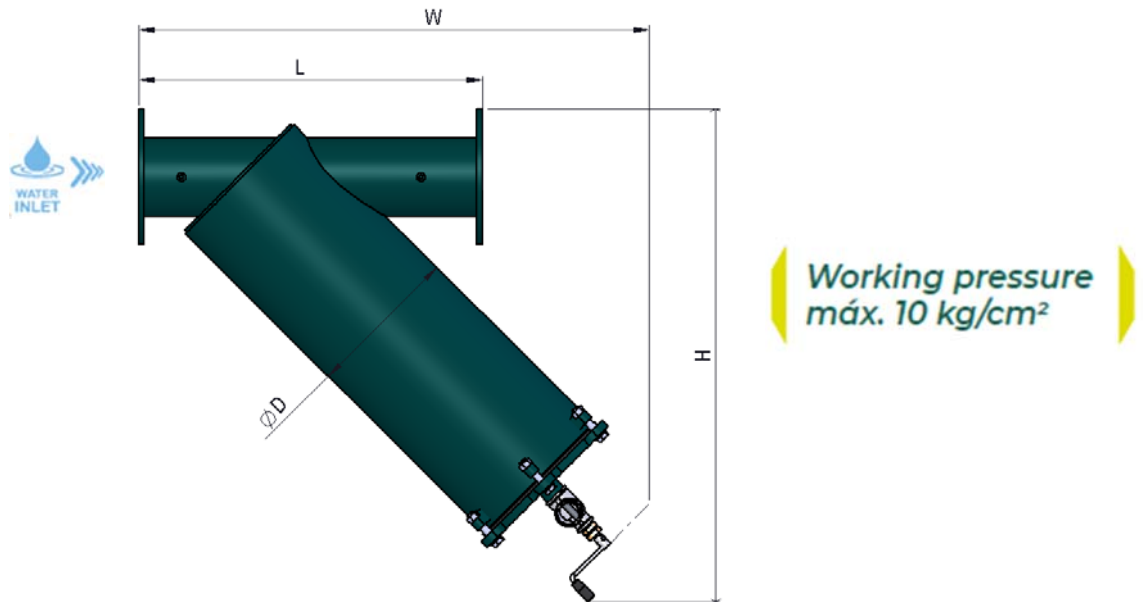

IMAGE 2

MODEL	ØI/ØO	Flow (m ³ /h)	Filtration Surface (cm ²)	Net Weight (kg)	Filter opening	Dimensions (mm)			
		Mesh Cartridge (Drip)				ØD	L	H	W
FY-CM-2"-M	Male Thread 2"	39	1500	13	Screws	165	450	503	450
FY-CM-3"-M	Flange 3"	57	2006	22	Screws	165	495	577	495
FY-CM-4"-M	Flange 4"	66	3160	40	Screws	220	695	710	695
FY-CM-5"-M	Flange 5"	80	3160	42	Screws	220	695	710	695
FY-CM-6"-M	Flange 6"	120	5579	71	Screws	323	725	1010	730
FY-CM-8"-M	Flange 8"	140	11040	163	Screws	355	1000	1100	1285

*Ask about other pressures

TABLE 1

2.2 Manufacturing technical characteristics

- Materials:
 - o Carbon steel metal components.
 - o Zinc plated screws 6.8.
 - o Mesh cartridge : PVC structure with AISI-316 Stainless Steel. Filtration degree: 125 microns.
 - o EPDM gaskets: 60 SHORE.
- Superficial treatment:
 - o Surface shot blasting up to SA ½ grade.
 - o Two-layer EPOXY-POLYESTER powder paint finish, oven-polymerized RAL 6004.
- Working characteristics:
 - o Maximum operating temperature 50°C.

3. INSTALLATION

1. Make sure the filter flow direction is correct.
2. Place the inlet and outlet manifolds, fixing the flanges with their corresponding gaskets.
3. Place the pressure gauges, one on the inlet manifold and the other on the water outlet manifold.
4. Carry out a first manual cleaning of the filter mesh.
5. Check that the unions are tight, turn on the water supply and verify that there are no leaks.
6. Filtering. Open the water flow at the recommended flow rate and at a working pressure of 10 kg/cm².
7. Clean the filter when the pressure gauges indicate a pressure difference equal to or greater than 0.5 kg/cm².
8. Cleaning. Disconnect the water flow and open the filter, depending on the model, by loosening the handle or the Screws. Remove the cap and then the filter, clean it by applying high pressure water to its outer surface and use a bristle brush on the inside if necessary. Replace and close the filter ensuring that the cap fits tightly.

4. OPERATION AND MAINTENANCE

Mesh filtering consists in the physical separation between water and the substances that are suspended in it. When the mesh filter becomes clogged, it produces a pressure difference between the water inlet and outlet. The manual cleaning cycle is necessary when reaching a pressure difference of 0,5 kg/cm². The water passes from the internal area of the filter to the external one causing the accumulation of dirt in the internal part of the mesh.

Maintenance necessary for proper operation: review of joints, paint and brushes. With use, the brushes may wear out and there may not be enough contact with the cartridge. In this case, loosen the brush screws and move them 5mm further outwards. Re-tighten the brushes and check that they are working properly before closing the cartridge. With use, the brushes may wear out and there may not be enough contact with the cartridge. In this case, loosen the brush screws and move them 5mm further outwards. Re-tighten the brushes and check that they are working properly before closing the cartridge.

5. SPARE PARTS

5.1 Exploded view FY Manual Brush Cleaning

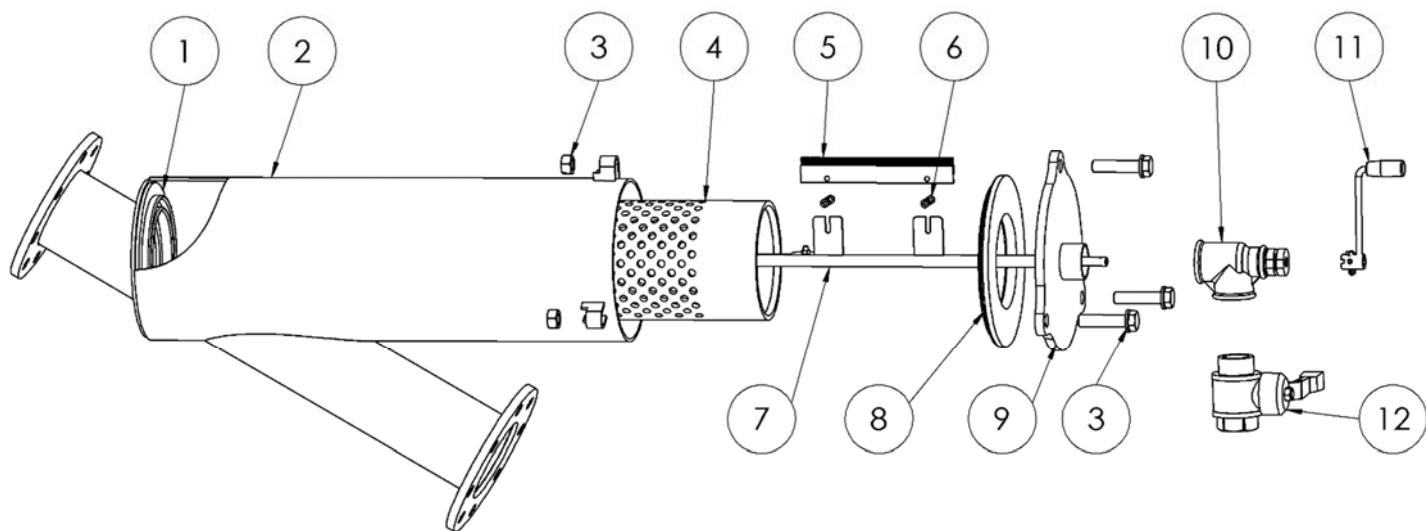

Nº	DENOM.	FY-CM MODELS											
		FY-CM-2"		FY-CM-3"		FY-CM-4"		FY-CM-5"		FY-CM-6"		FY-CM-8"	
		U.	Code	U.	Code	U.	Code	U.	Code	U.	Code	U.	Code
1	Lower Gasket	1	FY-2-08	1	FY-2-08	1	FY-4-220-08	1	FY-4-220-08	1	FY-6-08	1	HYD-206-H-05-2-2
2	Body	1	FY-2-02	1	FY-3-02	1	FY-4-02	1	FY-5-02	1	FY-6-02	1	FY-8-02
3	Screws M16	3	-	3	-	3	-	3	-	6	-	8	-
4	Cartridge	1	FY-CM-2-03	1	FY-CM-3-03	1	FY-CM-4-03	1	FY-CM-5-03	1	FY-CM-6-03	1	FY-CM-8-03
5	Brush	2	-	2	-	3	-	3	-	4	-	5	-
6	Screws M6	4	-	4	-	6	-	6	-	8	-	10	-
7	Scanner	1	FY-CM-2-06	1	FY-CM-3-06	1	FY-CM-4-06	1	FY-CM-5-06	1	FY-CM-6-06	1	FY-CM-8-06
8	Upper Gasket	1	FY-2-09	1	FY-2-09	1	FY-4-220-09	1	FY-4-220-09	1	FY-6-09	1	HYD-206-H-07-04+Junta6
9	Cap	1	FY-CM-2-05	1	FY-CM-3-05	1	FY-CM-4-05	1	FY-CM-5-05	1	FY-CM-6-05	1	FY-CM-8-05
10	Centering T	1	-	1	-	1	-	1	-	1	-	1	-
11	Crank	1	-	1	-	1	-	1	-	1	-	1	-
12	Ball valve	1	-	1	-	1	-	1	-	1	-	1	-

TABLE 2

6. PRODUCT WARRANTY

1. All ITM FILTERS products are guaranteed for 1 year from the date of invoice.
2. The replacement of defective parts is covered by the warranty, being necessary to indicate the serial number and allow the verification by our staff.
3. Take into account the user manual for the installation of the product and check the operating parameters in the technical tables.
4. To obtain a correct filtration, the size of the filter element must be smaller than that of the substances suspended in the water to be filtered.
5. This warranty will not apply in the event of damage or defects produced in the product as a result of or related to:
 - i. Tearing, elimination or manipulation of the identifying label of the product.
 - ii. Improper or unauthorized use of the product by the buyer.
 - iii. An improper assembly or installation that does not correspond to that established by ITM FILTERS.
 - iv. The pertinent periodic cleanings.
 - v. The use of water that does not meet the established quality or is outside the specifications indicated in the technical tables.
 - vi. A use of flow discordant with the water quality according to the parameters defined in the technical tables.
 - vii. Pressures that differ from the established working pressure.
 - viii. The wear of materials caused by fatigue, abrasion or high temperatures.
 - ix. Any external alteration, modification or repair of the products, except by ITM FILTERS and its technical representatives.
 - x. Damages produced during the transport of the product.
 - xi. Third party damage, theft or vandalism.
6. At ITM FILTERS we are committed to quality, which is why we have the ISO 9001, ISO 14001 and ISO 45001 certifications. In addition, during the manufacture of our filters we have established our own quality control in which we ensure that the product meets all quality requirements optimally. If you notice any defects, please contact your dealer.
7. For any claim, it is essential to present this document, the serial code of the corresponding product and the purchase invoice.



Water Solutions



INTRAMESA MZ S.A.



Polígono Armentera P-99

22400 Monzón (Huesca)

www.itmfilters.com

info@itmfilters.com

Tel. 974 10 50 05