



DATA SHEET

METALIC MANUAL FILTER FY-CM MANUAL BRUSH CLEANING



1. FY Manual Brush Cleaning

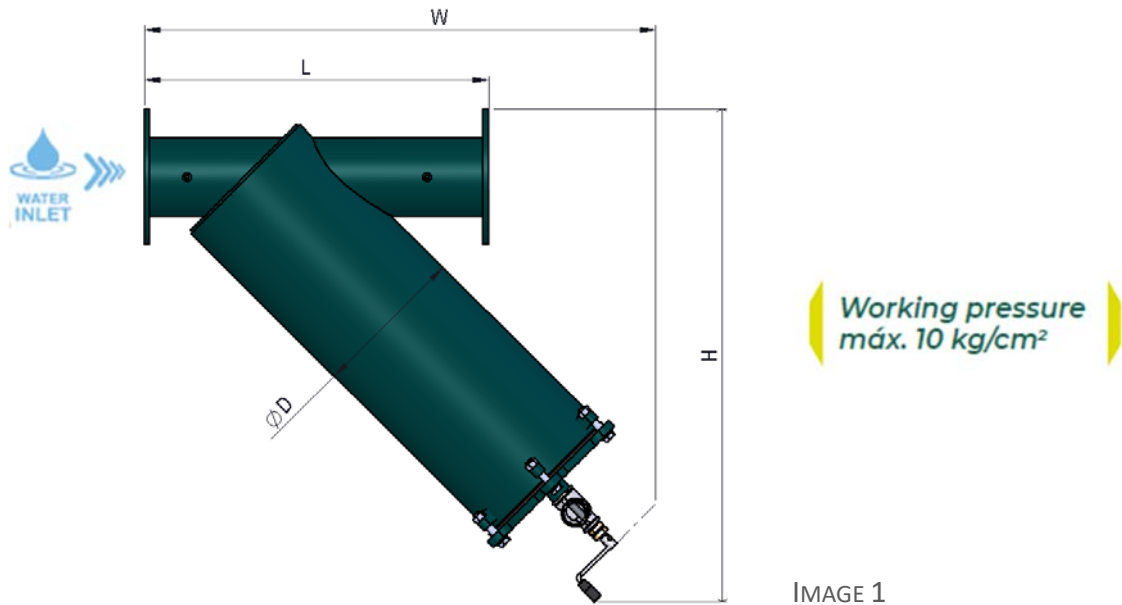

MODEL	ØI/ØO	Flow (m³/h)	Filtration Surface (cm²)	Net Weight (kg)	Filter opening	Dimensions (mm)			
		Mesh Cartridge (Drip)				ØD	L	H	W
FY-CM-2"-M	Male Thread 2"	39	1500	13	Screws	165	450	503	450
FY-CM-3"-M	Flange 3"	57	2006	22	Screws	165	495	577	495
FY-CM-4"-M	Flange 4"	66	3160	40	Screws	220	695	710	695
FY-CM-5"-M	Flange 5"	80	3160	42	Screws	220	695	710	695
FY-CM-6"-M	Flange 6"	120	5579	71	Screws	323	725	1010	730
FY-CM-8"-M	Flange 8"	140	11040	163	Screws	355	1000	1100	1285

TABLE 1

*Ask about other pressures

2. Manufacturing technical characteristics

- **Materials:**
 - o Carbon steel metal components.
 - o Zinc plated screws 6.8.
 - o Mesh cartridge : PVC structure with AISI-316 Stainless Steel. Filtration degree: 125 microns.
 - o EPDM gaskets: 60 SHORE.
- **Superficial treatment:**
 - o Surface shot blasting up to SA ½ grade.
 - o Two-layer EPOXY-POLYESTER powder paint finish, oven-polymerized RAL 6004.
- **Working characteristics:**
 - o Maximum operating temperature 50°C.



Water Solutions



INTRAMESA MZ S.A.

**Polígono Armentera P-99
22400 Monzón (Huesca)**

www.itmfilters.com

info@itmfilters.com

Tel. 974 10 50 05