



---

## DATA SHEET

---

# METALIC MANUAL FILTER FY-CM MANUAL BRUSH CLEANING



## 1. FY MANUAL BRUSH CLEANING

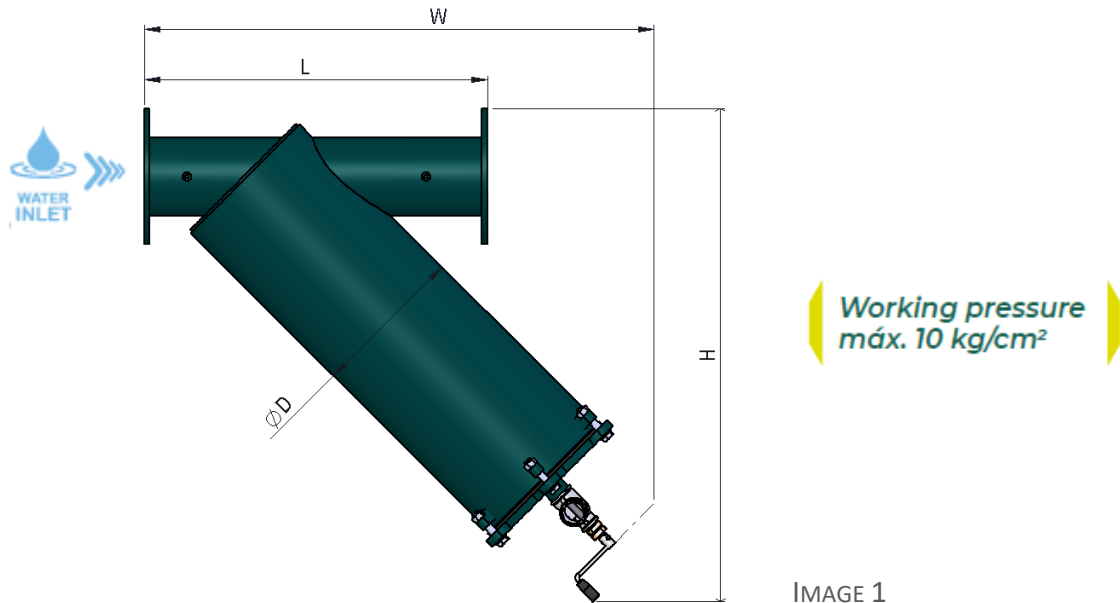

MODEL	ØI/ØO	Flow (m <sup>3</sup> /h)	Filtration Surface (cm <sup>2</sup> )	Net Weight (kg)	Filter opening	Dimensions (mm)			
		Mesh Cartridge (Drip)				ØD	L	H	W
FY-CM-2"-M	Male Thread 2"	39	1500	13	Screws	165	450	503	450
FY-CM-3"-M	Flange 3"	57	2006	22	Screws	165	495	577	495
FY-CM-4"-M	Flange 4"	66	3160	40	Screws	220	695	710	695
FY-CM-5"-M	Flange 5"	80	3160	42	Screws	220	695	710	695
FY-CM-6"-M	Flange 6"	120	5579	71	Screws	323	725	1010	730
FY-CM-8"-M	Flange 8"	140	11040	163	Screws	355	1000	1100	1285

TABLE 1

\*Ask about other pressures

## 2. MANUFACTURING TECHNICAL CHARACTERISTICS

- **Materials:**
  - Carbon steel metal components.
  - Zinc plated screws 8.8.
  - Mesh cartridge : PVC structure with AISI-316 Stainless Steel. Filtration degree: 125 microns.
  - EPDM gaskets: 60 SHORE.
- **Superficial treatment:**
  - Surface shot blasting up to SA ½ grade.
  - Two-layer EPOXY-POLYESTER powder paint finish, oven-polymerized RAL 6004.
- **Working characteristics:**
  - Maximum operating temperature 50°C.



Water Solutions



**ITM WATER SYSTEMS, S.A.**



**Polígono Armentera P-99  
22400 Monzón (Huesca)**

**[www.itmfilters.com](http://www.itmfilters.com)**

**[info@itmwater.com](mailto:info@itmwater.com)**

**Tel. 974 10 50 05**