



DATA SHEET

METALIC MANUAL FILTER METALLIC Y FILTER (FY-M)



1. METALLIC Y FILTER (FY-M)

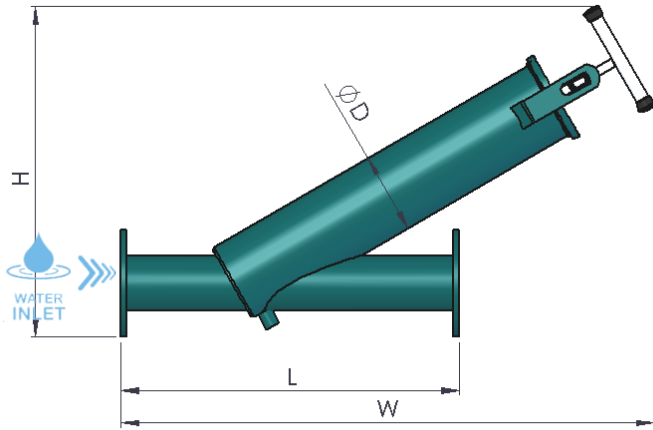

IMAGE 1

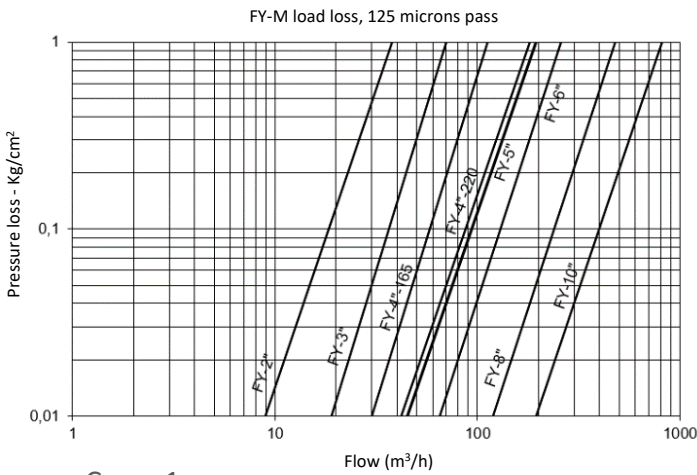
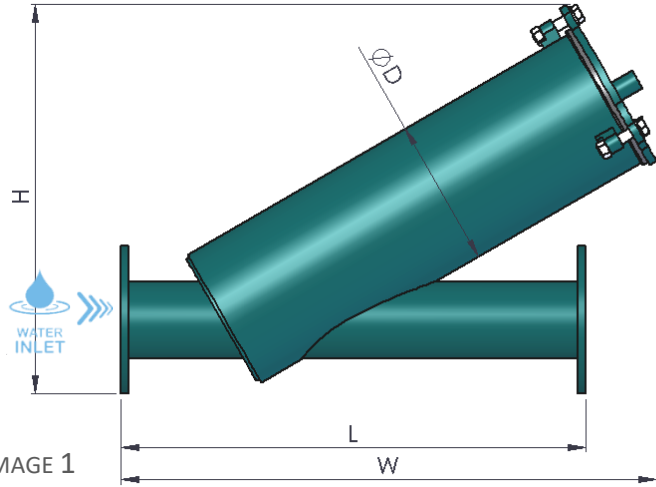

CHART 1

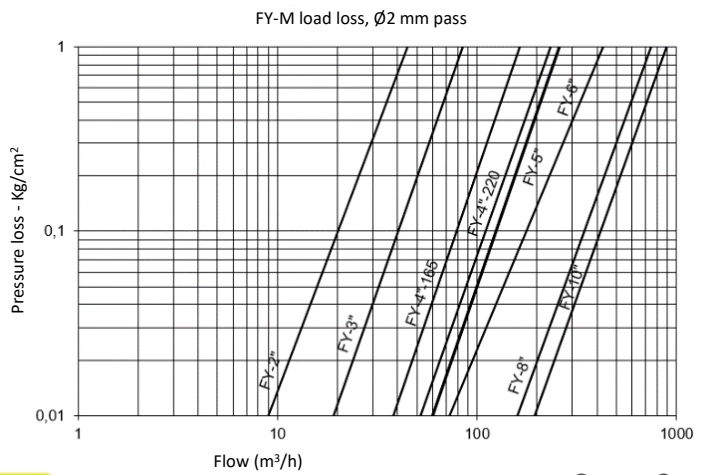

CHART 2

Working pressure
máx. 10 kg/cm²

MODEL	ØI/ØO	Flows (m ³ /h)		Filtration Surface (cm ²)	Net Weight (kg)	Filter opening	Dimensions (mm)			
		Mesh Cartridge (Drip)	Ø2 mm Cartridge (Sprinkler)				ØD	L	H	W
FY-2"-M	Male Thread 2"	21	26	1500	12	Wing Nut	165	450	470	613
FY-3"-M	Flange 3"	42	51	2006	21	Wing Nut	165	495	542	757
FY-4"-165-M	Flange 4"	83	97	3007	25	Wing Nut	165	695	678	1096
FY-4"-220-M	Flange 4"	104	121	3160	36	Screws	220	695	580	801
FY-5"-M	Flange 5"	128	155	3160	38	Screws	220	695	595	801
FY-6"-M	Flange 6"	152	185	5579	66	Screws	323	725	924	990
FY-8"-M	Flange 8"	301	365	11040	135	Screws	355	1000	1137	1323
FY-10"-M	Flange 10"	402	485	13700	163	Screws	355	1000	1356	1515

TABLE 1

*Ask about other pressures

2. MANUFACTURING TECHNICAL CHARACTERISTICS

- Materials:
 - Carbon steel metal components.
 - Zinc plated screws 6.8.
 - Mesh cartridge : PVC structure with AISI-316 Stainless Steel. Filtration degree: 125 microns.
 - Grinding cartridge: AISI-304 Stainless Steel. Ø2 mm pass.
 - EPDM gaskets: 60 SHORE.

- Superficial treatment:
 - Surface shot blasting up to SA ½ grade.
 - Two-layer EPOXY-POLYESTER powder paint finish, oven-polymerized RAL 6004.

- Working characteristics:
 - Maximum operating temperature 50°C.



Water Solutions



INTRAMESA MZ S.A.



**Polígono Armentera P-99
22400 Monzón (Huesca)**

www.itmfilters.com

info@itmfilters.com

Tel. 974 10 50 05