



DATA SHEET

HYDRANT PROTECTION FILTERS X PATTERN STRAINER (FCX)



1. X PATTERN STRAINER (FCX)

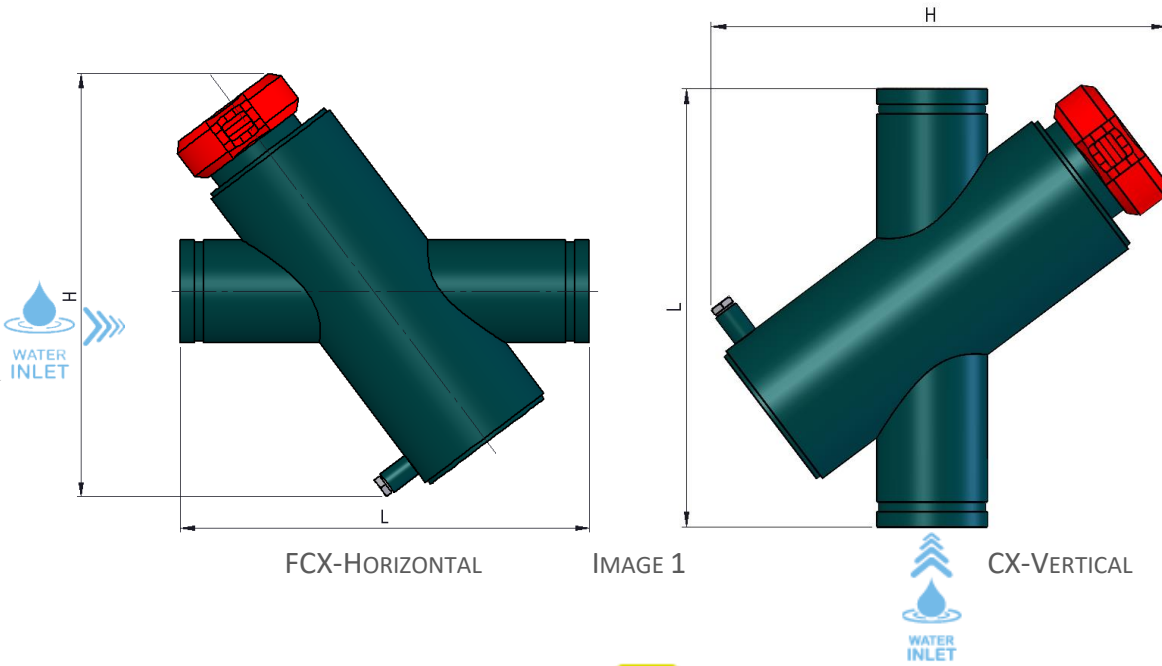

Stainless steel filter
cartridge Ø4mm
pitch

MODEL	ØI/ØO	Filtration Surface (cm ²)	Net Weight (kg)	Dimensions (mm)	
				ØD	L
FCX-2"-H	Male Thread 2"	1390	18	400	470
FCX-3"-H	Flange 3"	1390	21	400	470
FCX-4"-H	Flange 4"	1390	25	450	470
FCX-6"-H	Flange 6"	2760	31	670	630
FCX-8"-H	Flange 8"	4860	56	885	795
FCX-10"-H	Flange 10"	4860	61	900	795
FCX-2"-V	Male Thread 2"	1390	18	400	470
FCX-3"-V	Flange 3"	1390	21	400	470
FCX-4"-V	Flange 4"	1390	25	450	470
FCX-6"-V	Flange 6"	2760	31	670	630
FCX-8"-V	Flange 8"	4860	56	885	795
FCX-10"-H	Flange 10"	4860	61	900	795

TABLE 1



IMAGE 2

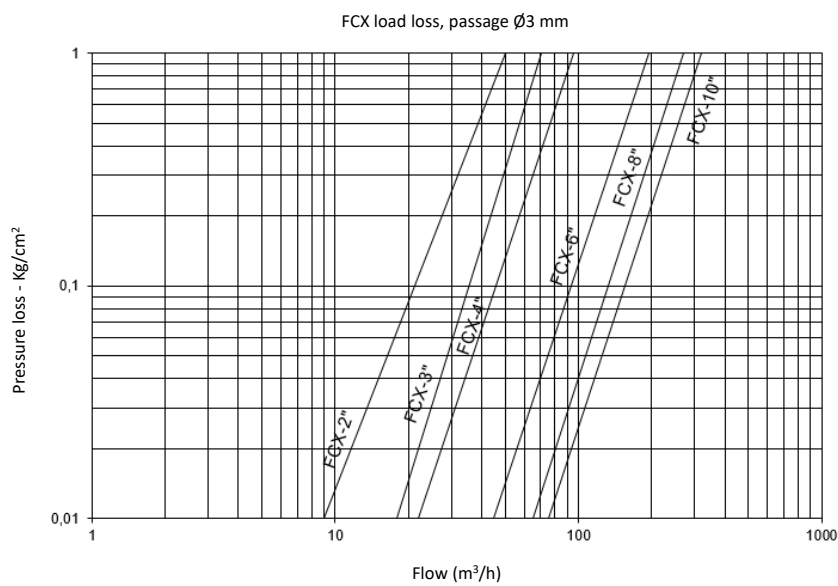

CHART 1

2. MANUFACTURING TECHNICAL CHARACTERISTICS

- **Materials:**
 - Carbon steel metal components.
 - Zinc plated screws 6.8.
 - Grinding cartridge : Stainless Steel AISI-304. $\varnothing 3$ mm pass
 - EPDM gaskets: 60 SHORE.
- **Superficial treatment:**
 - Surface shot blasting up to SA $\frac{1}{2}$ grade.
 - Two-layer EPOXY-POLYESTER powder paint finish, oven-polymerized RAL 6004.
- **Working characteristics:**
 - Maximum operating temperature 50°C.



Water Solutions



INTRAMESA MZ S.A.



Polígono Armentera P-99

22400 Monzón (Huesca)

www.itmfilters.com

info@itmfilters.com

Tel. 974 10 50 05