



DATA SHEET

HYDRANT PROTECTION FILTERS
L PATTERN STRAINER (FCL)



1. L PATTERN STRAINER (FCL)

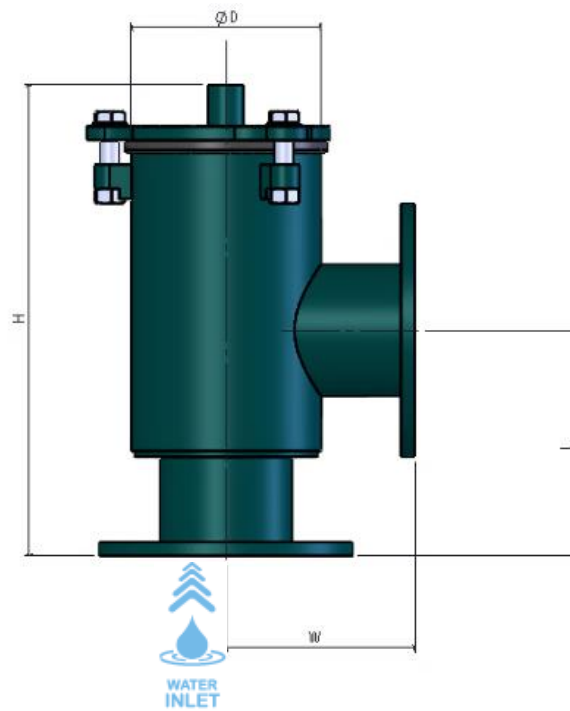

IMAGE 1

*Stainless steel filter
cartridge Ø4mm
pitch*

MODEL	ØI/ØO	Filtration Surface (cm ²)	Net Weight (kg)	Dimensions (mm)			
				ØD	L	H	W
FCL-2"	Male Thread 2"	590	9	165	138	273	138
FCL-3"	Flange 3"	795	14	165	192	353	164
FCL-4"	Flange 4"	1020	16	165	196	410	164
FCL-5"	Flange 5"	1500	19	220	265	525	200
FCL-6"	Flange 6"	1530	27	220	250	475	200
FCL-8"	Flange 8"	2700	49	323	300	590	250
FCL-10"	Flange 10"	4895	71	406	380	785	300
FCL-12"	Flange 12"	5895	93	406	400	785	300

TABLE 1



IMAGE 2

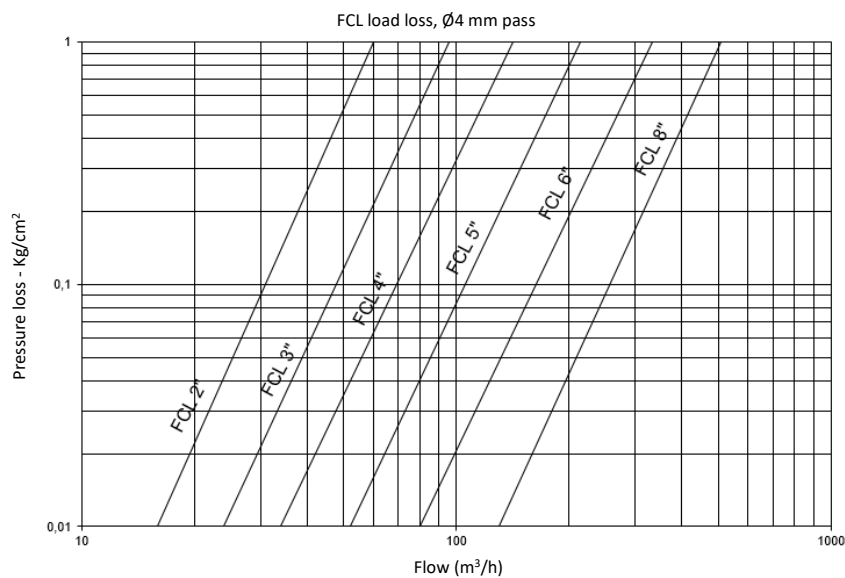

CHART 1

2. MANUFACTURING TECHNICAL CHARACTERISTICS

- **Materials:**
 - Carbon steel metal components.
 - Zinc plated screws 6.8.
 - Grinding cartridge : Stainless Steel AISI-304. Ø4 mm pass
 - EPDM gaskets: 60 SHORE.
- **Superficial treatment:**
 - Surface shot blasting up to SA ½ grade.
 - Two-layer EPOXY-POLYESTER powder paint finish, oven-polymerized RAL 6004.
- **Working characteristics:**
 - Maximum operating temperature 50°C.



Water Solutions



INTRAMESA MZ S.A.



Polígono Armentera P-99

22400 Monzón (Huesca)

www.itmfilters.com

info@itmfilters.com

Tel. 974 10 50 05